

KEP Operator Interfaces INDEX

New Products	PAGE 2	See what's new at KEP.
<u>MMI8000 Series Operator Interfaces</u>	<u>PAGE</u>	<u>DESCRIPTION</u>
MMI8056	3	5.6" Color Graphic Display Panel with Touch Screen
MMI8080	7	8.0" Color Graphic Display Panel with Touch Screen
MMI8104	11	10.4" Color Graphic Display Panel with Touch Screen
MMI8121	15	12.1" Color Graphic Display Panel with Touch Screen
<u>MMI-500 Series Operator Interfaces</u>	<u>PAGE</u>	<u>DESCRIPTION</u>
MMI-430T	19	4.3" Color Graphic Display Panel and Touch Screen
MMI-730T	22	5.6" Color Graphic Display Panel and Touch Screen
MMI-Cover	24	5.6", 7.7", 10.4" Protective Overlays for MMI-500 and MMI8000 Series Touchscreen Displays
<u>Message Centers/Text Interfaces</u>	<u>PAGE</u>	<u>DESCRIPTION</u>
MMI-10	25	Message center
MMI-40	26	Message center with 4 line display
MMI-100	27	Message center with function keys
MMI-110	29	Message center with data access
MMI-140	31	Message center with data access and 4 line display
MMI-220	32	Operator interface with 2 line display
MMI-240	34	Operator interface with 4 line display
<u>Industrial Flat Panel Monitors</u>	<u>PAGE</u>	<u>DESCRIPTION</u>
FPM	36	Industrial Flat Panel Touchscreen Monitors
<u>HMI Software</u>	<u>PAGE</u>	<u>DESCRIPTION</u>
Infilink-HMI	38	HMI software package
KEPServerEX	41	OPC/DDE server software package
<u>Slave Displays</u>	<u>PAGE</u>	<u>DESCRIPTION</u>
S12	42	LED , BCD to 7 segment display which accepts full parallel BCD or multiplexed inputs
<u>Accessories</u>	<u>PAGE</u>	<u>DESCRIPTION</u>
TWTB/TWSTB	44	Thumbwheel switches which provide easy access to change PLC register values
RSW	46	Rotary BCD switch, sealed to NEMA 4X specifications
SMIC Cables	48	Smart Interface Cables for KEP Operator Interfaces

New Products

MMI8000 Series

Color Graphic Display Panels and Touch Screens. Available with several display sizes.



See Pages 3 through 15 for Details

MMI-430T

4.3" Color Graphic Display Panel and Touch Screen



See Page 19 for Details

MMI-8056

5.6" Color Graphic Display Panel and Touch Screen

Features

- Bright 5.6" TFT LCD 65536 Color Display
- NEMA4/IP65 Compliant Front Panel
- Built-in Flash Memory
- One Compactflash™ Slot
- 2 USB Ports
- Ethernet Modbus TCP/IP; Ethernet I/P
- 2 RS232 and 3 RS485 ports
- Supports Multiple PLC Types to one MMI
- Data Logging to USB, CF Card
- 6 Levels of User Security for up to 12 Users
- True Type Font Capability
- Alarm and Alarm History (Events) Tracking
- Real time and Historical Trending
- Multiple Language Support (up to 7 languages)
- Simple scripting for Advanced Users (Macro)
- Free Design Mode, Windowstm Based Setup Software Included



Introduction

The MMI8056 is a compact HMI platform. This new and improved design comes very close to mimicking an Industrial PC. Its 32-bit RISC kernel delivers impressive performance at low power. A hardware graphics acceleration engine gives superior 65K color graphics performance. This leaves more time for Data management.

The MMI8056 has features for Data logging and Compact Flash Card or USB Stick type memory storage. Data information can also be accessed by SCADA/HMI software running on remote PC's via Ethernet. MMI to MMI communications are easily done through Ethernet. With its many features the MMI8056 is the sensible choice for present and future Operator Interface applications.

Integration Guide

Supported Peripherals

Ethernet

Multiple MMIs can be connected via high speed Ethernet to improve the efficiency of data transfer



CF Card

Provides standard CF card slot



Disk On Module

Supports standard 44-pin IDE interface slot (not available on MMI8056)

USB Barcode Device

Supports USB barcode device



Sound Out

Connect with sound device to output warning signals



Wireless Device

Use with wireless devices to build a wireless environment

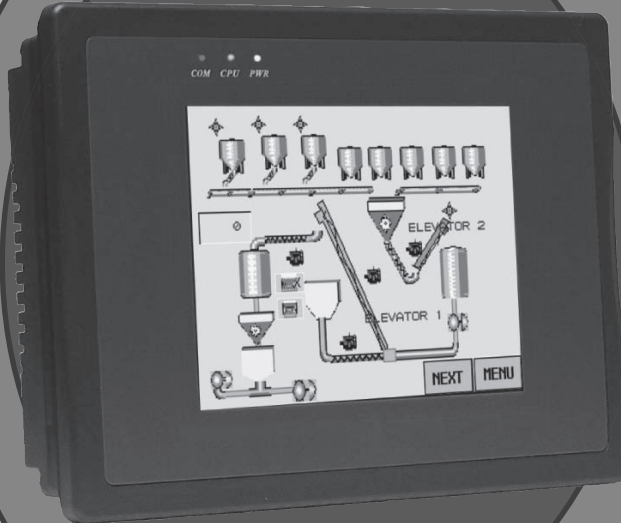

USB Printer

Connect a USB printer for data printing



USB Keyboard

Supports USB keyboard

USB Mouse

Supports USB mouse



RS232/RS485 2w/4w Port

Connect with multiple PLCs and controllers simultaneously



USB Memory Stick

Supports USB memory stick

Specifications	
Construction:	plastic molding housing
Display:	5.6" 320x234 65536 color TFT LCD
CPU:	32 bit RISC
System DRAM:	64 MB on board
Storage:	32 MB flash memory on board, 1 CompactFlash™ card slot,
I/O: 3 serial ports:	COM1: RS232/RS485 (2 or 4Wire) COM2: RS232 COM3: RS232/RS485(2 Wire)
Ethernet:	1 Ethernet port (10/100Base-T)
USB:	2 USB 2.0 full-speed host (12Mbps)
Sound output:	Yes
RTC:	Built-in
Power input:	24 VDC, 0.5A maximum

LCD Display	
Display type	TFT color LCD
Display size (diagonal)	5.6"
Max colors	65536
Resolution	320 x 234
Pixel pitch (HxV, mm)	0.2535 x 0.2535
Viewing angle ()	55/65/65/65 (T/B/R/L)
Luminance (cd/m2)	350
Storage temperature (C)	-25~70
Operating temperature (C)	0~45
Backlight	LED
Contrast ratio	250:1

Touchscreen	
Type:	4-wire, analog resistive
Resolution:	continuous
Light transmission:	above 80%
Life:	1 million activation minimal

Environmental Specifications	
Operating temperature:	0 ~ 45C (32 ~ 113F)
Relative humidity:	10% ~ 90% @ 40C, non-condensing
Shock (operation):	10 to 25Hz(X,Y,Z direction 2G 30minutes)
EMI:	Complies with FCC Class A
CE :	Complies with EN50081-2 and EN50082-2 standards
Front panel:	NEMA4 / IP65

EasyBuilder Software Specification	
Screen editor	EasyBuilder Ver. EB8000 1.0.1 or later (requires Windows 2000, XP)
No. of window	Up to 1989 Windows
No. of object	Up to 500 per window, limited by memory
Text strings	limited only by memory
Graphics	Supports BMP, GIF and JPG
PLC Support	Most popular PLC's
Macro Scripts	Easy to use macro scripting language
System Requirements	Computer requirements: Pentium III or higher CPU, 64 MB RAM, 2.5 GB Hard Disk Space with 10 MB available, 256-color VGA 1024 x 768 display, Keyboard and Mouse, available Ethernet port, Windows XP or Windows 2000.
EB8000 Setup and Features	<p>EasyBuilder has a complete set of drawing tools as well as the ability to import and place bitmaps. Summary of EasyBuilder Objects</p> <p>Bit Lamp – Bit triggered indicators</p> <p>Word Lamp – Word controlled indicators</p> <p>Set Bit – Button press sets bit On, OFF, toggle, hold, or automatically change bit on timer, window change, backlight activation.</p> <p>Set Word – Button press sets or jogs word or automatically changes word on window or backlight change</p> <p>Toggle Switch – Toggles, holds or sets a bit</p> <p>MultiState Switch – Increment/Decrement a word</p> <p>Slider – Drag a shape to change digital data.</p> <p>Function Button – Perform a system operation</p> <p>Numeric Input / Display – Change/Display digital data</p> <p>ASCII Input / Display – Change/Display alphanumeric data</p> <p>X,Y Move Animation – Move an object via pixel coordinates</p> <p>Spot Move Animation – Move an object on a predefined path</p> <p>Direct Window – Popup Window on Bit status change</p> <p>Indirect Window – Popup Window depending on Word's value</p> <p>Trend Graph – Plots data on a trend</p> <p>Data History Display – Show contents of Data Logger</p> <p>Meter – Display data as circular meters</p> <p>Alarm Display ,Scrolling Alarm – Display predefined text strings in response to bit or word changes</p> <p>Event Display – Display and log predefined text strings in response to bit or word changes</p> <p>Backup – Move Events to external memory</p> <p>Data Transfer – Move data to and from the PLC</p> <p>PLC Controls: Change window, Backlight control, Macro Execution, Data Transfer</p>

Ordering Information	
Part Number	Description
MMI8056	Graphic Interface with 5.6" Color LCD display and Touchscreen, Replaces MMI-730T,MMI-730T-E, MMI-750 and MMI-750T

Installation Guide

Dimensions are in mm (inches)

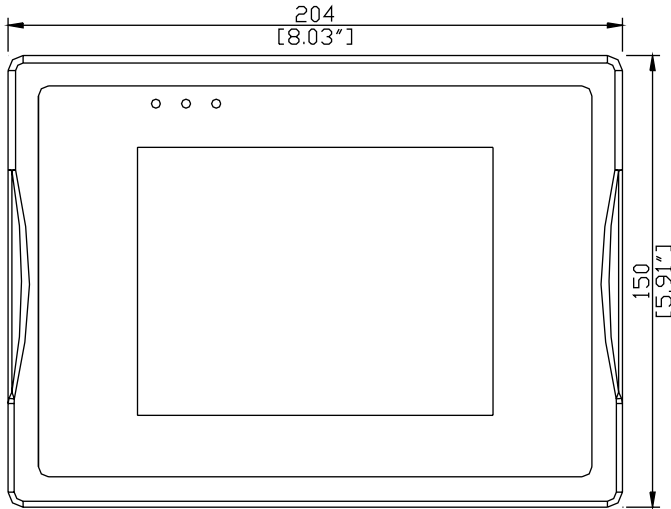

Front View

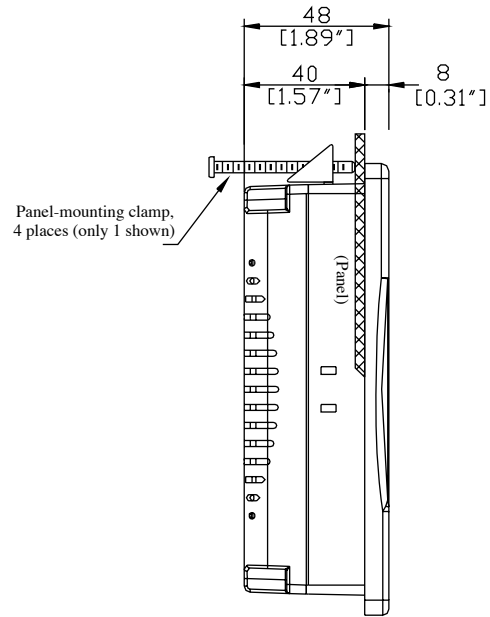

Side View

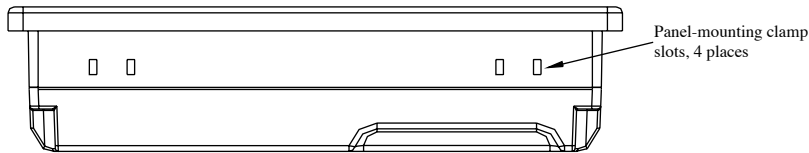

Bottom View

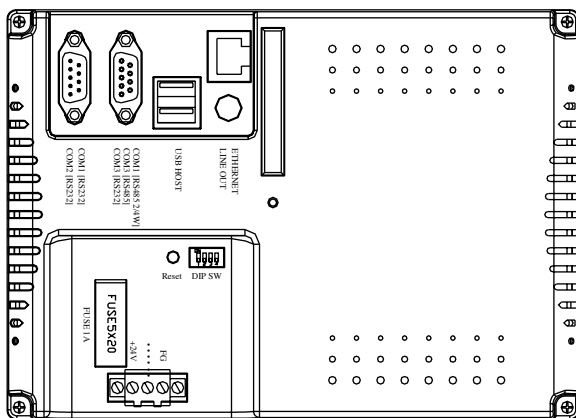

Rear View

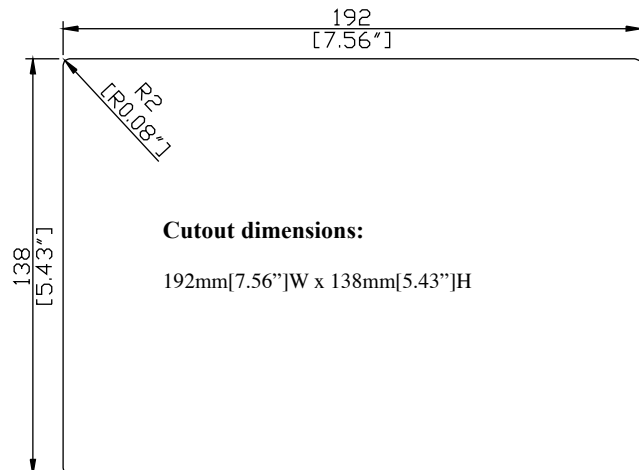

Cutout dimensions:
192mm[7.56"]W x 138mm[5.43"]H

MMI-8080

8.0" Color Graphic Display Panel and Touch Screen

Features

- Bright 8.0" TFT LCD 65536 Color Display
- NEMA4/IP65 Compliant Front Panel
- Built-in Flash Memory
- One Compactflash™ Slot
- 3 USB Ports
- Ethernet Modbus TCP/IP; Ethernet I/P
- 2 RS232 and 3 RS485 ports
- Supports Multiple PLC Types to one MMI
- Data Logging to USB, CF Card
- 6 Levels of User Security for up to 12 Users
- True Type Font Capability
- Alarm and Alarm History (Events) Tracking
- Real time and Historical Trending
- Multiple Language Support (up to 7 languages)
- Simple scripting for Advanced Users (Macro)
- Free Design Mode, Windowstm Based Setup Software Included



Introduction

The MMI8080 is a compact HMI platform. This new and improved design comes very close to mimicking an Industrial PC. Its 32-bit RISC kernel delivers impressive performance at low power. A hardware graphics acceleration engine gives superior 65K color graphics performance. This leaves more time for Data management.

The MMI8080 has features for Data logging and Compact Flash Card or USB Stick type memory storage. Data information can also be accessed by SCADA/HMI software running on remote PC's via Ethernet. MMI to MMI communications are easily done through Ethernet. With its many features the MMI8080 is the sensible choice for present and future Operator Interface applications.

Integration Guide

Supported Peripherals

Ethernet

Multiple MMIs can be connected via high speed Ethernet to improve the efficiency of data transfer



CF Card

Provides standard CF card slot



Disk On Module

Supports standard 44-pin IDE interface slot (not available on MMI8056)

USB Barcode Device

Supports USB barcode device



Sound Out

Connect with sound device to output warning signals



Wireless Device

Use with wireless devices to build a wireless environment



USB Mouse

Supports USB mouse



RS232/RS485 2w/4w Port

Connect with multiple PLCs and controllers simultaneously



USB Memory Stick

Supports USB memory stick



USB Printer

Connect a USB printer for data printing

USB Keyboard

Supports USB keyboard

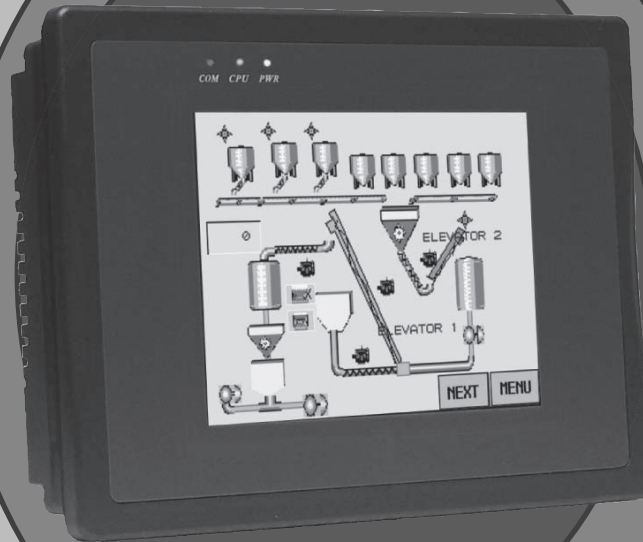

Specifications	
Construction:	plastic molding housing
Display:	8.0" 640x480 65536 color TFT LCD
CPU:	32 bit RISC
System DRAM:	64 MB on board
Storage:	32 MB flash memory on board, 1 CompactFlash™ card slot, 44-pin IDE interface
I/O: 3 serial ports:	COM1: RS232/RS485 (2 or 4 Wire) COM2: RS232 COM3: RS232/RS485 (2 Wire)
Ethernet:	1 Ethernet port (10/100Base-T)
USB:	2 USB 2.0 full-speed host (12Mbps)
Sound output:	Yes
RTC:	Built-in
Power input:	24 VDC, 0.5A maximum

LCD Display	
Display type	TFT color LCD
Display size (diagonal)	8.0"
Max colors	65536
Resolution	640 x 480
Pixel pitch (HxV, mm)	0.2535 x 0.2535
Viewing angle ()	55/65/65/65 (T/B/R/L)
Luminance (cd/m2)	400
Storage temperature (C)	-25~70
Operating temperature (C)	0~45
Backlight	CCFL x 1
Contrast ratio	250:1

Touchscreen	
Type:	4-wire, analog resistive
Resolution:	continuous
Light transmission:	above 80%
Life:	1 million activation minimal

Environmental Specifications	
Operating temperature:	0 ~ 45C (32 ~ 113F)
Relative humidity:	10% ~ 90% @ 40C, non-condensing
Shock (operation):	10 to 25Hz(X,Y,Z direction 2G 30minutes)
EMI:	Complies with FCC Class A
CE :	Complies with EN50081-2 and EN50082-2 standards
Front panel:	NEMA4 / IP65

EasyBuilder Software Specification	
Screen editor	EasyBuilder Ver. EB8000 1.0.1 or later (requires Windows 2000, XP)
No. of window	Up to 1989 Windows
No. of object	Up to 500 per window, limited by memory
Text strings	limited only by memory
Graphics	Supports BMP, GIF and JPG
PLC Support	Most popular PLC's
Macro Scripts	Easy to use macro scripting language
System Requirements	Computer requirements: Pentium III or higher CPU, 64 MB RAM, 2.5 GB Hard Disk Space with 10 MB available, 256-color VGA 1024 x 768 display, Keyboard and Mouse, available Ethernet port, Windows XP or Windows 2000.
EB8000 Setup and Features	<p>EasyBuilder has a complete set of drawing tools as well as the ability to import and place bitmaps. Summary of EasyBuilder Objects</p> <p>Bit Lamp – Bit triggered indicators</p> <p>Word Lamp – Word controlled indicators</p> <p>Set Bit – Button press sets bit On, OFF, toggle, hold, or automatically change bit on timer, window change, backlight activation.</p> <p>Set Word – Button press sets or jogs word or automatically changes word on window or backlight change</p> <p>Toggle Switch – Toggles, holds or sets a bit</p> <p>MultiState Switch – Increment/Decrement a word</p> <p>Slider – Drag a shape to change digital data.</p> <p>Function Button – Perform a system operation</p> <p>Numeric Input / Display – Change/Display digital data</p> <p>ASCII Input / Display – Change/Display alphanumeric data</p> <p>X,Y Move Animation – Move an object via pixel coordinates</p> <p>Spot Move Animation – Move an object on a predefined path</p> <p>Direct Window – Popup Window on Bit status change</p> <p>Indirect Window – Popup Window depending on Word's value</p> <p>Trend Graph – Plots data on a trend</p> <p>Data History Display – Show contents of Data Logger</p> <p>Meter – Display data as circular meters</p> <p>Alarm Display ,Scrolling Alarm – Display predefined text strings in response to bit or word changes</p> <p>Event Display – Display and log predefined text strings in response to bit or word changes</p> <p>Backup – Move Events to external memory</p> <p>Data Transfer – Move data to and from the PLC</p> <p>PLC Controls: Change window, Backlight control, Macro Execution, Data Transfer</p>

Ordering Information	
Part Number	Description
MMI8080	Graphic Interface with 8.0" Color LCD display and Touchscreen,

Installation Guide

Dimensions are in mm (inches)

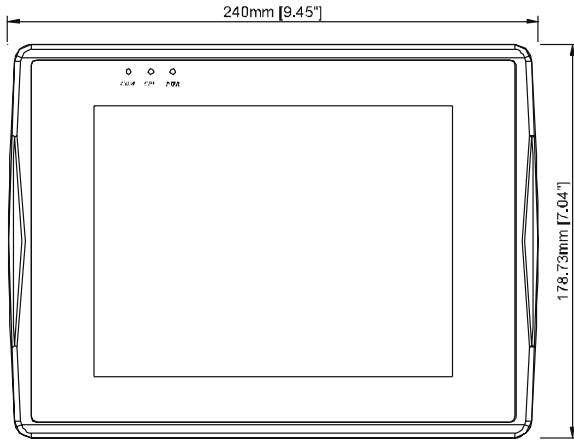

Front View

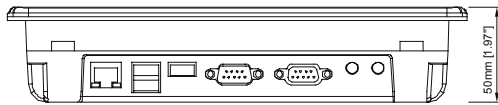

Bottom View

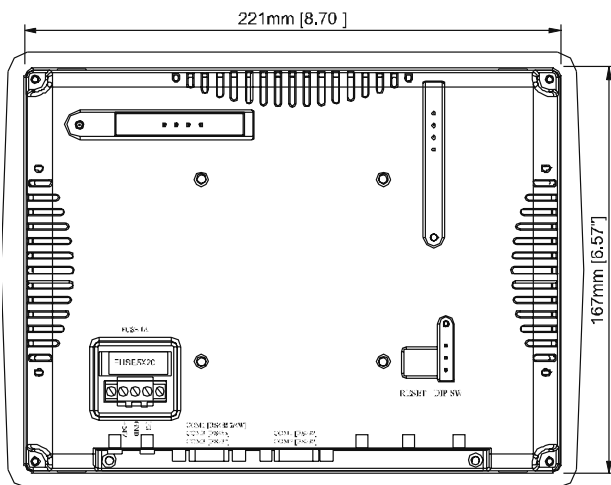

Rear View

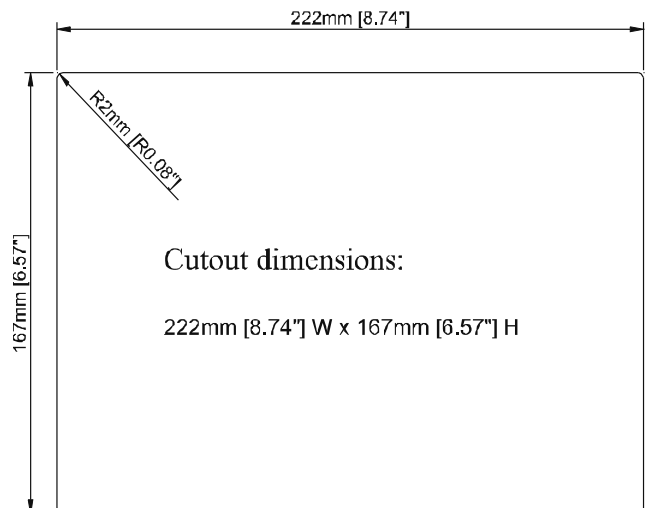

Panel Cutout

MMI-8104

10.4" Color Graphic Display Panel and Touch Screen

Features

- Bright 10.4" TFT LCD 65536 Color Display
- NEMA4/IP65 Compliant Front Panel
- Built-in Flash Memory
- One Compactflash™ Slot
- 3 USB Ports
- Ethernet Modbus TCP/IP; Ethernet I/P
- 2 RS232 and 3 RS485 ports
- Supports Multiple PLC Types to one MMI
- Data Logging to USB, CF Card
- 6 Levels of User Security for up to 12 Users
- True Type Font Capability
- Alarm and Alarm History (Events) Tracking
- Real time and Historical Trending
- Multiple Language Support (up to 7 languages)
- Simple scripting for Advanced Users (Macro)
- Free Design Mode, Windowstm Based Setup Software Included



Introduction

The MMI8104 is a compact HMI platform. This new and improved design comes very close to mimicking an Industrial PC. Its 32-bit RISC kernel delivers impressive performance at low power. A hardware graphics acceleration engine gives superior 65K color graphics performance. This leaves more time for Data management.

The MMI8104 has features for Data logging and Compact Flash Card or USB Stick type memory storage. Data information can also be accessed by SCADA/HMI software running on remote PC's via Ethernet. MMI to MMI communications are easily done through Ethernet. With its many features the MMI8104 is the sensible choice for present and future Operator Interface applications.

Integration Guide

Supported Peripherals

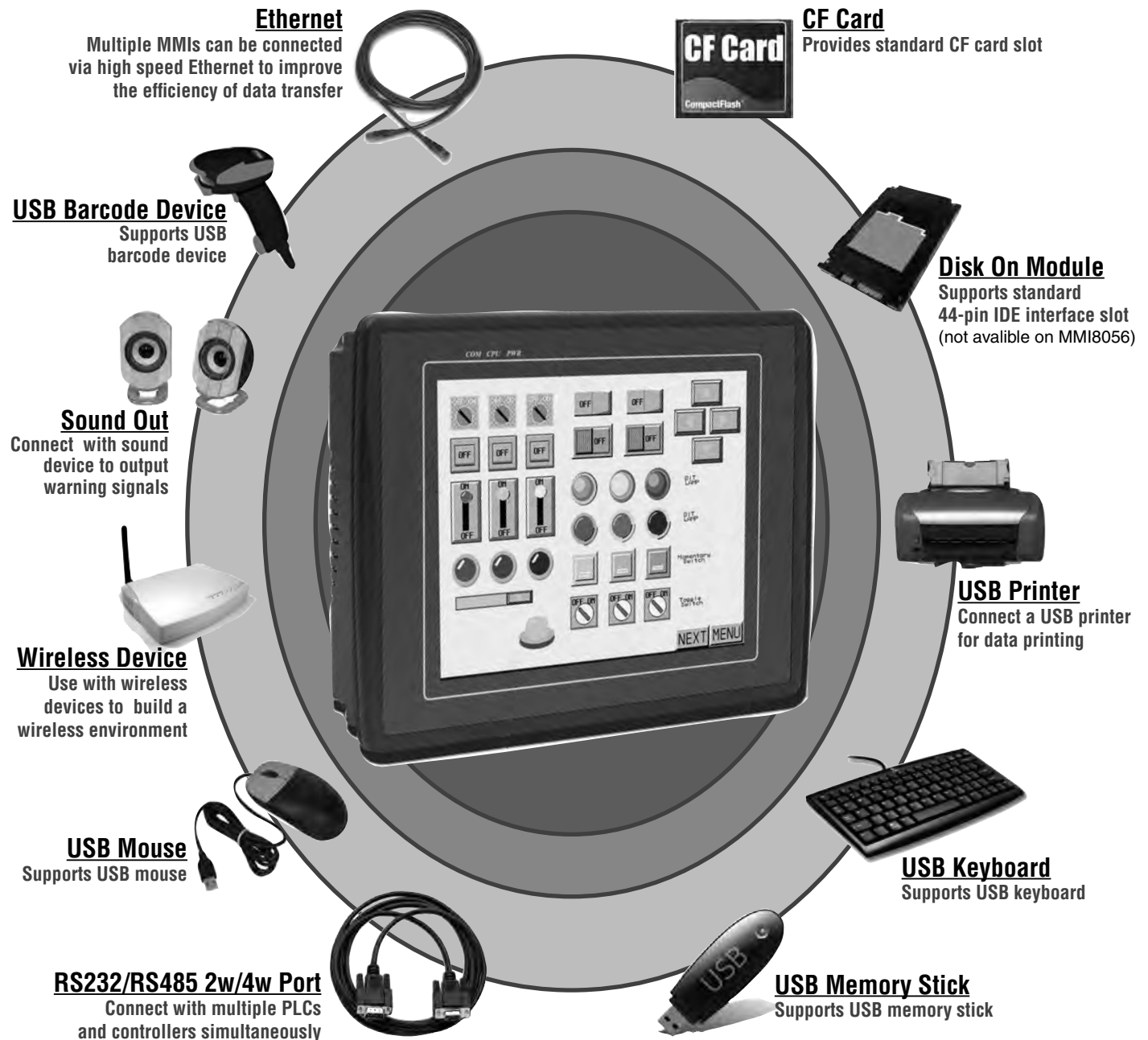

Specifications	
Construction:	plastic molding housing
Display:	10.4" 640x480 65536 color TFT LCD
CPU:	32 bit RISC
System DRAM:	64 MB on board
Storage:	32 MB flash memory on board, 1 CompactFlash™ card slot, 44-pin IDE interface
I/O: 3 serial ports:	COM1: RS232/RS485 (2 or 4 Wire) COM2: RS232 COM3: RS232/RS485 (2 Wire)
Ethernet:	1 Ethernet port (10/100Base-T)
USB:	3 USB 2.0 full-speed host (12Mbps)
Sound output:	Yes
RTC:	Built-in
Power input:	24 VDC, 0.5A maximum

LCD Display	
Display type	TFT color LCD
Display size (diagonal)	10.4"
Max colors	65536
Resolution	640 x 480
Pixel pitch (HxV, mm)	0.2535 x 0.2535
Viewing angle ()	55/65/65/65 (T/B/R/L)
Luminance (cd/m2)	400
Storage temperature (C)	-25~70
Operating temperature (C)	0~45
Backlight	CCFL x 1
Contrast ratio	300:1

Touchscreen	
Type:	4-wire, analog resistive
Resolution:	continuous
Light transmission:	above 80%
Life:	1 million activation minimal

Environmental Specifications	
Operating temperature:	0 ~ 45C (32 ~ 113F)
Relative humidity:	10% ~ 90% @ 40C, non-condensing
Shock (operation):	10 to 25Hz(X,Y,Z direction 2G 30minutes)
EMI:	Complies with FCC Class A
CE :	Complies with EN50081-2 and EN50082-2 standards
Front panel:	NEMA4 / IP65

EasyBuilder Software Specification	
Screen editor	EasyBuilder Ver. EB8000 1.0.1 or later (requires Windows 2000, XP)
No. of window	Up to 1989 Windows
No. of object	Up to 500 per window, limited by memory
Text strings	limited only by memory
Graphics	Supports BMP, GIF and JPG
PLC Support	Most popular PLC's
Macro Scripts	Easy to use macro scripting language
System Requirements	Computer requirements: Pentium III or higher CPU, 64 MB RAM, 2.5 GB Hard Disk Space with 10 MB available, 256-color VGA 1024 x 768 display, Keyboard and Mouse, available Ethernet port, Windows XP or Windows 2000.
EB8000 Setup and Features	<p>EasyBuilder has a complete set of drawing tools as well as the ability to import and place bitmaps. Summary of EasyBuilder Objects</p> <p>Bit Lamp – Bit triggered indicators</p> <p>Word Lamp – Word controlled indicators</p> <p>Set Bit – Button press sets bit On, OFF, toggle, hold, or automatically change bit on timer, window change, backlight activation.</p> <p>Set Word – Button press sets or jogs word or automatically changes word on window or backlight change</p> <p>Toggle Switch – Toggles, holds or sets a bit</p> <p>MultiState Switch – Increment/Decrement a word</p> <p>Slider – Drag a shape to change digital data.</p> <p>Function Button – Perform a system operation</p> <p>Numeric Input / Display – Change/Display digital data</p> <p>ASCII Input / Display – Change/Display alphanumeric data</p> <p>X,Y Move Animation – Move an object via pixel coordinates</p> <p>Spot Move Animation – Move an object on a predefined path</p> <p>Direct Window – Popup Window on Bit status change</p> <p>Indirect Window – Popup Window depending on Word's value</p> <p>Trend Graph – Plots data on a trend</p> <p>Data History Display – Show contents of Data Logger</p> <p>Meter – Display data as circular meters</p> <p>Alarm Display ,Scrolling Alarm – Display predefined text strings in response to bit or word changes</p> <p>Event Display – Display and log predefined text strings in response to bit or word changes</p> <p>Backup – Move Events to external memory</p> <p>Data Transfer – Move data to and from the PLC</p> <p>PLC Controls: Change window, Backlight control, Macro Execution, Data Transfer</p>

Ordering Information	
Part Number	Description
MMI8104	Graphic Interface with 10.4" Color LCD display and Touchscreen,

Installation Guide

Dimensions are in mm (inches)

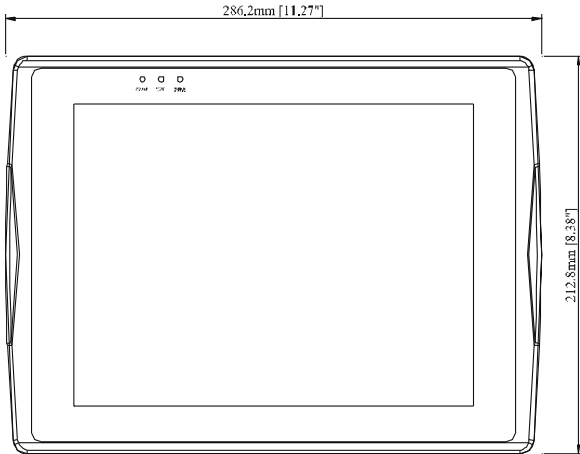

Front View

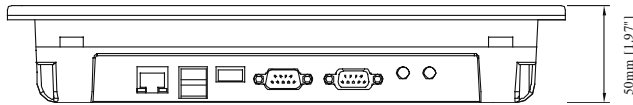

Bottom View

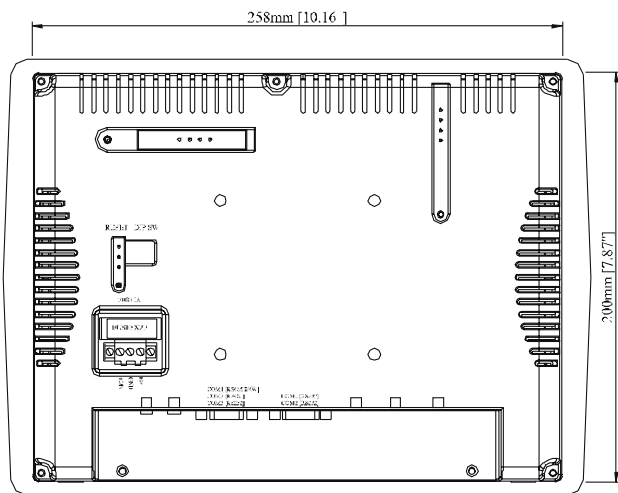

Rear View

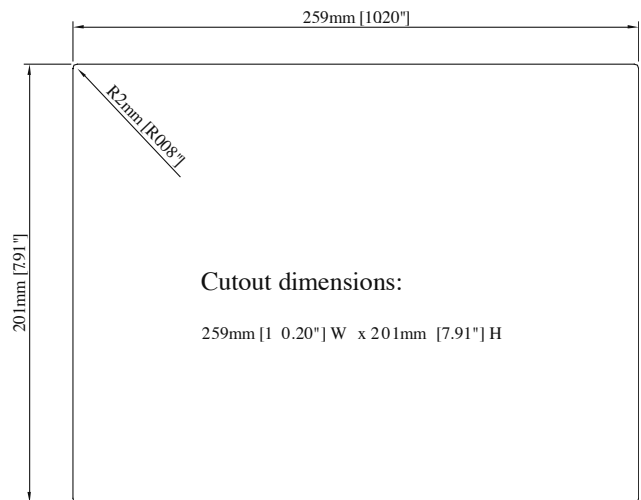

Panel Cutout

MMI-8121

12.1" Color Graphic Display Panel and Touch Screen

Features

- Bright 12.1" TFT LCD 65536 Color Display
- NEMA4/IP65 Compliant Front Panel
- Built-in Flash Memory
- One Compactflash™ Slot
- 3 USB Ports
- Ethernet Modbus TCP/IP; Ethernet I/P
- 2 RS232 and 3 RS485 ports
- Supports Multiple PLC Types to one MMI
- Data Logging to USB, CF Card
- 6 Levels of User Security for up to 12 Users
- True Type Font Capability
- Alarm and Alarm History (Events) Tracking
- Real time and Historical Trending
- Multiple Language Support (up to 7 languages)
- Simple scripting for Advanced Users (Macro)
- Free Design Mode, Windowstm Based Setup Software Included



Introduction

The MMI8121 is a compact HMI platform. This new and improved design comes very close to mimicking an Industrial PC. Its 32-bit RISC kernel delivers impressive performance at low power. A hardware graphics acceleration engine gives superior 65K color graphics performance. This leaves more time for Data management.

The MMI8121 has features for Data logging and Compact Flash Card or USB Stick type memory storage. Data information can also be accessed by SCADA/HMI software running on remote PC's via Ethernet. MMI to MMI communications are easily done through Ethernet. With its many features the MMI8121 is the sensible choice for present and future Operator Interface applications.

Integration Guide

Supported Peripherals

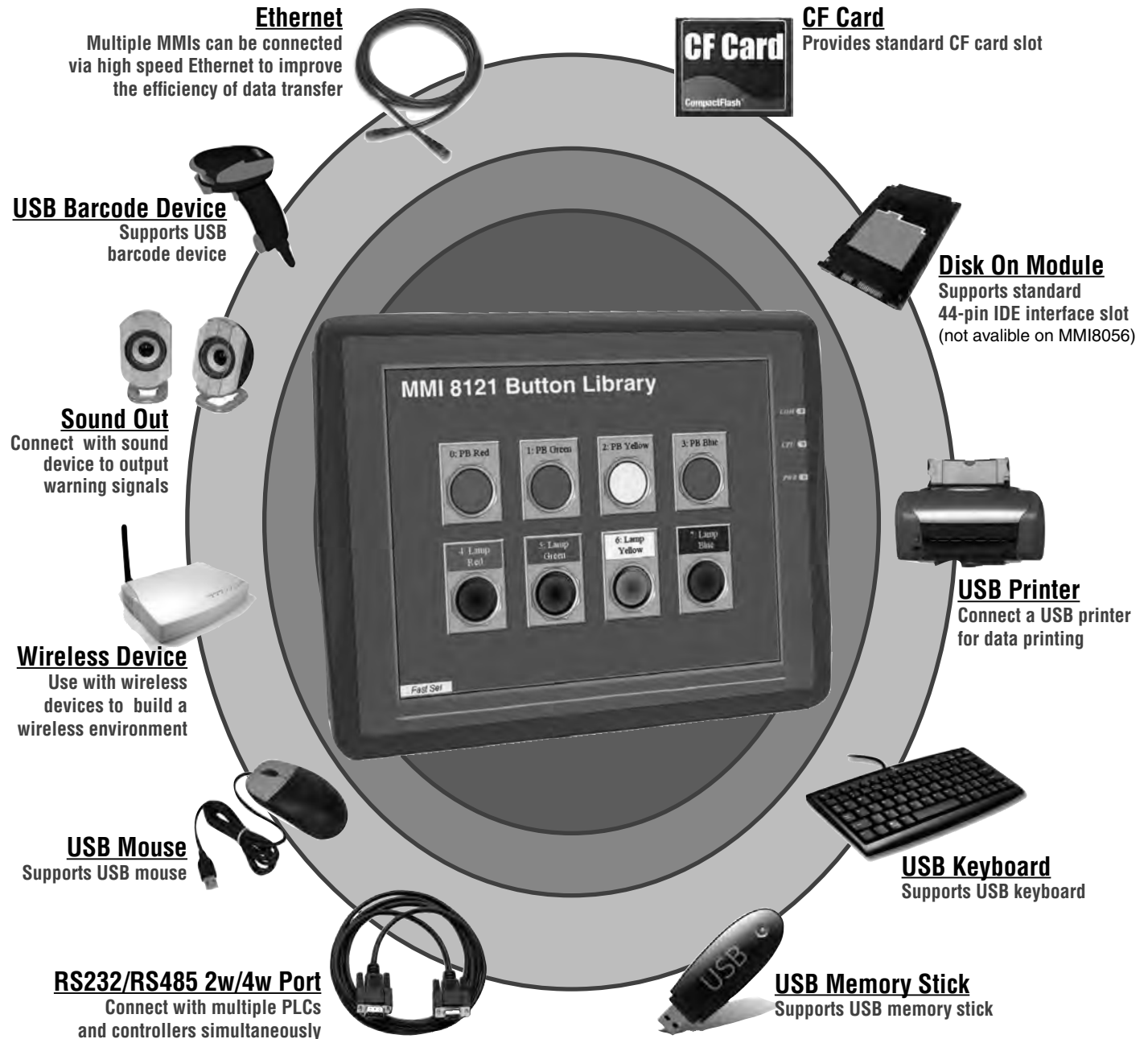

Specifications	
Construction:	plastic molding housing
Display:	12.1" 800 x 600 65536 color TFT LCD
CPU:	32 bit RISC
System DRAM:	64 MB on board
Storage:	32 MB flash memory on board, 1 CompactFlash™ card slot, 44-pin IDE interface
I/O: 3 serial ports:	COM1: RS232/RS485 (2 or 4 Wire) COM2: RS232 COM3: RS232/RS485 (2 Wire)
Ethernet:	1 Ethernet port (10/100Base-T)
USB:	3 USB 2.0 full-speed host (12Mbps)
Sound output:	Yes
RTC:	Built-in
Power input:	24 VDC, 0.5A maximum

LCD Display	
Display type	TFT color LCD
Display size (diagonal)	12.1"
Max colors	65536
Resolution	800 x 600
Pixel pitch (HxV, mm)	0.3075 x 0.3075
Viewing angle ()	95 (Upper+Lower), 120 (Left+Right)
Luminance (cd/m2)	300
Storage temperature (C)	-20~60
Operating temperature (C)	0~45
Backlight	CCFL x 2
Contrast ratio	200:1

Touchscreen	
Type:	4-wire, analog resistive
Resolution:	continuous
Light transmission:	above 80%
Life:	1 million activation minimal

Environmental Specifications	
Operating temperature:	0 ~ 45C (32 ~ 113F)
Relative humidity:	10% ~ 90% @ 40C, non-condensing
Shock (operation):	10 to 25Hz(X,Y,Z direction 2G 30minutes)
EMI:	Complies with FCC Class A
CE :	Complies with EN50081-2 and EN50082-2 standards
Front panel:	NEMA4 / IP65

EasyBuilder Software Specification	
Screen editor	EasyBuilder Ver. EB8000 1.0.1 or later (requires Windows 2000, XP)
No. of window	Up to 1989 Windows
No. of object	Up to 500 per window, limited by memory
Text strings	limited only by memory
Graphics	Supports BMP, GIF and JPG
PLC Support	Most popular PLC's
Macro Scripts	Easy to use macro scripting language
System Requirements	Computer requirements: Pentium III or higher CPU, 64 MB RAM, 2.5 GB Hard Disk Space with 10 MB available, 256-color VGA 1024 x 768 display, Keyboard and Mouse, available Ethernet port, Windows XP or Windows 2000.
EB8000 Setup and Features	<p>EasyBuilder has a complete set of drawing tools as well as the ability to import and place bitmaps. Summary of EasyBuilder Objects</p> <p>Bit Lamp – Bit triggered indicators</p> <p>Word Lamp – Word controlled indicators</p> <p>Set Bit – Button press sets bit On, OFF, toggle, hold, or automatically change bit on timer, window change, backlight activation.</p> <p>Set Word – Button press sets or jogs word or automatically changes word on window or backlight change</p> <p>Toggle Switch – Toggles, holds or sets a bit</p> <p>MultiState Switch – Increment/Decrement a word</p> <p>Slider – Drag a shape to change digital data.</p> <p>Function Button – Perform a system operation</p> <p>Numeric Input / Display – Change/Display digital data</p> <p>ASCII Input / Display – Change/Display alphanumeric data</p> <p>X,Y Move Animation – Move an object via pixel coordinates</p> <p>Spot Move Animation – Move an object on a predefined path</p> <p>Direct Window – Popup Window on Bit status change</p> <p>Indirect Window – Popup Window depending on Word's value</p> <p>Trend Graph – Plots data on a trend</p> <p>Data History Display – Show contents of Data Logger</p> <p>Meter – Display data as circular meters</p> <p>Alarm Display ,Scrolling Alarm – Display predefined text strings in response to bit or word changes</p> <p>Event Display – Display and log predefined text strings in response to bit or word changes</p> <p>Backup – Move Events to external memory</p> <p>Data Transfer – Move data to and from the PLC</p> <p>PLC Controls: Change window, Backlight control, Macro Execution, Data Transfer</p>

Ordering Information	
Part Number	Description
MMI8121	Graphic Interface with 12.1" Color LCD display and Touchscreen,

Installation Guide

Dimensions are in mm (inches)

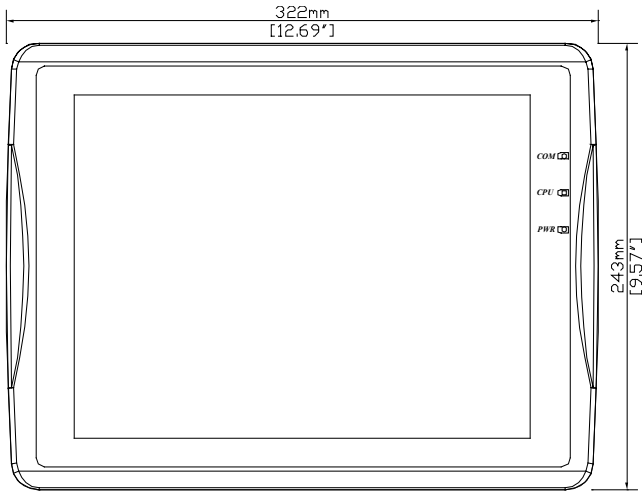

Front View

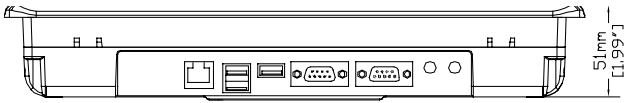

Bottom View

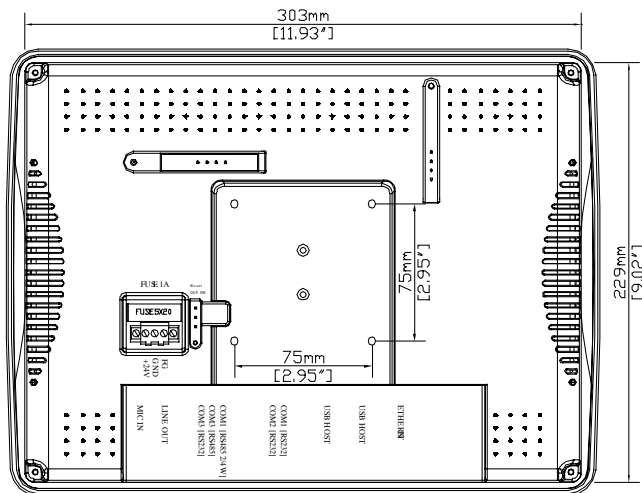

Rear View

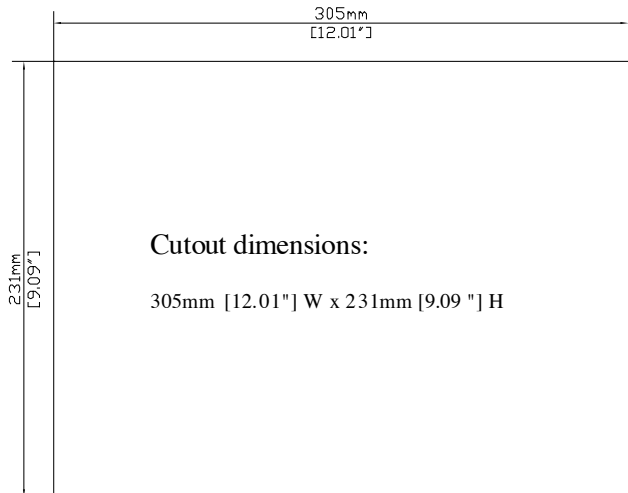

Cutout dimensions:

305mm [12.01"] W x 231mm [9.09"] H

Panel Cutout

MMI-430T

4.3" Color Graphic Display Panel and Touch Screen

Features

- 480 x 272, 256 Colors, TFT LCD Display
- 32 Bit Risc
- Compact Size
- NEMA4 / IP65 Compliant Front Panel
- RS232/485 4/2 Wire Port

Introduction

The MMI430T is a powerful operator interface in a compact package. This unit brings out the PLC's full potential and improves production line efficiency. Its bright crisp display increases operator awareness of machine or process conditions. This improves operator safety and reduces downtime. Reduce panel size and costs by putting buttons, data and meters on the MMI-430T's touch-screen display. Wiring is reduced to power and a cable to the PLC. Easy to install, easy to connect and easy to program.



Specifications

Construction:	plastic molding housing
Display:	480 x 272 256 color TFT LCD
CPU:	32 bit RISC
System DRAM:	4 MB on board
Storage:	2 MB flash memory on board,
I/O: 3 serial ports:	1 RS232 port (PC-HMI) 1 RS232/485 port (HMI-PLC)
RTC:	none
Power input:	12~28 VDC, 0.3A @12V, 0.15A @24V
Weight:	Approx. 0.3kg
Software:	EB500 V2.7.3 or later

LCD Display

Display type	TFT color LCD
Display size (diagonal)	4.3"
Max colors	256
Resolution	489 x 272
Pixel pitch (HxV, mm)	0.198 x 0.198
Viewing angle (°)	80/80/80/80 (T/B/R/L)
Luminance (cd/m2)	300
Storage temperature (C)	-30° ~ 70°C (240hrs)
Operating temperature (C)	0° ~ 45°C (32° ~ 113°F)
Backlight	LED
Backlight Life	80,000 hrs
Contrast ratio	400:1

Ordering Information

Part Number	Description
MMI-430T	Graphic Interface with 4.3" Color LCD display and Touchscreen, includes programming cable, RS232 breakout cable and setup software.

EasyBuilder Software Specification	
Screen editor	EasyBuilder V2.7.3 or later (requires Windows 2000, XP)
No. of window	Up to 1989 Windows
No. of object	Up to 500 per window, limited by memory
Text strings	limited only by memory
Graphics	Supports BMP, GIF and JPG
PLC Support	Most popular PLC's
Macro Scripts	Easy to use macro scripting language
System Requirements	Computer requirements include at least a Pentium 90Mhz PC, 16MB RAM, 10MB available hard disk space, minimum 800x600 resolution VGA, and one available RS-232 serial port.

Touchscreen	
Type:	4-wire, analog resistive
Resolution:	continuous
Light transmission:	above 80%
Life:	1 million activation minimal

Environmental Specifications	
Operating temperature:	0 ~ 45C (32 ~ 113F)
Relative humidity:	10% ~ 80% @ 40°C, non-condensing
Shock (operation):	10 to 25Hz (X,Y,Z direction 2G 30minutes)
EMI:	Complies with FCC Class A
CE :	Complies with EN50081-2 and EN50082-2 standards
Front panel:	NEMA4 / IP65

EB8000 Setup and Features	EasyBuilder has a complete set of drawing tools as well as the ability to import and place bitmaps. Summary of EasyBuilder Objects
	Bit Lamp – Place an indicator that is bit triggered
	Word Lamp – Place an indicator that is word triggered
	Set Bit – Set a bit on a button press, button hold, window change, backlight activation or data entry.
	Set Word – Set a word on a button press, button hold, window change, backlight activation or data entry.
	Toggle Switch – Toggle a bit
	MultiState Switch – Increment/Decrement a word
	Function Button – Perform a system operation
	Numeric Input / Display – Change/Display digital data
	ASCII Input / Display – Change/Display alphanumeric data
	X,Y Move Animation – Move an object via pixel coordinates
	Spot Move Animation – Move an object on a predefined path
	Direct Window – Popup Window on Bit status change
	Indirect Window – Popup Window depending on Word's value
	Alarm Display – display predefined text strings in response to bit changes
	Trend Graph – Plots active data on a trend
	Data History Display – Show contents of Data Logger
	Meter – Display one of 4 different types of meters
	Scrolling Alarm – display predefined text strings in response to bit changes
	Event Display – display and log predefined text strings in response to bit or word changes
	Data Transfer – move data to and from the PLC
	PLC Controls: Change window, Backlight control, Macro Execution, Data Transfer

Installation Guide

Dimensions are in mm (inches)

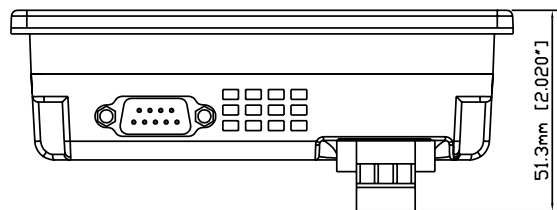
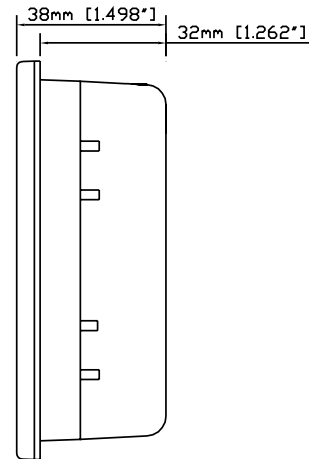
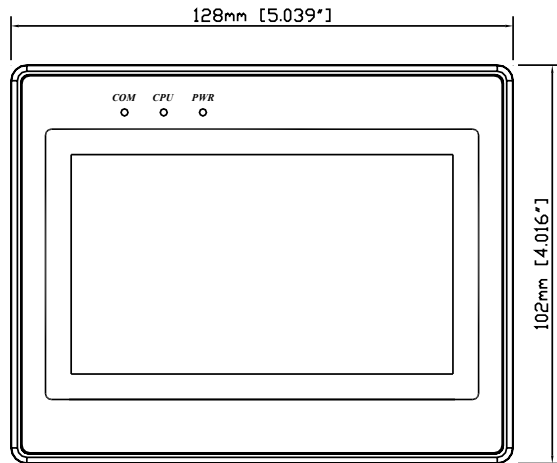

Rear View

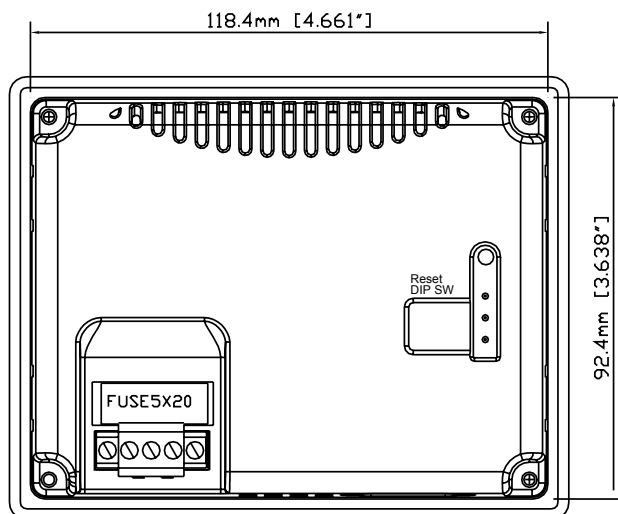
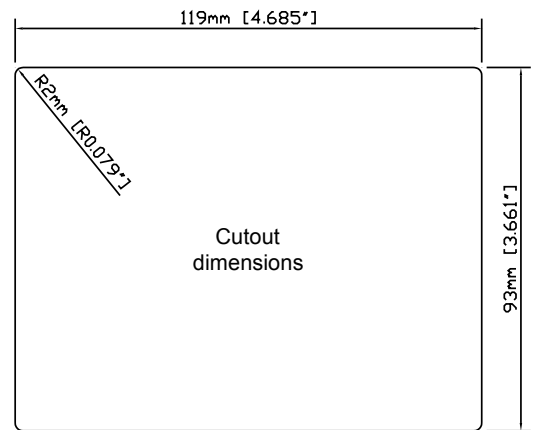

MMI-730T

Color Graphic Display Panel and Touch Screen

Features

- Bright 5.6" TFT 256 Color Display
- Analog Touch Screen Interface
- Connects to PLC's via Single Cable to Programming Port
- FREE Design Mode, Windows™ based Setup Software Included
- Intel® Xscale PXA255 200MHz processor
- Built-in Recipe memory and Real Time Clock



LCD with Touch Panel

The MMI-730T is a touch screen interface for programmable controllers. No special PLC programming is required for data access. The unit displays pictorial information, data and messages that are preloaded into it using a Personal Computer. Touch screen areas can be programmed to perform various functions. Free setup software for configuring the MMI-730T is included with each unit. The Easy Builder Screen Editor offers fast and intuitive configuration. This simplifies application design while reducing development costs. The MMI-730T is rated NEMA4/IP65 from the front when mounted properly. It is designed for industrial working environments.

Connect directly to most PLCs

The MMI-730T uses each PLC's communication protocol to read or write data. It supports RS232 and RS485 for direct connection to PLCs with a single cable. It does not require the PLC to run any special program for data communication. This allows the unit to be used with existing systems. If desired, the unit can be programmed to work in conjunction with the PLC, responding to PLC commands. This brings out the PLC's full potential and improves operator efficiency. The MMI-730T allows the user to optimize communications by selecting the data block size that is uploaded with each communication to the PLC. The EasyWindow utility provided with EasyBuilder is used to further monitor and tweak PLC communication efficiencies.

Partial list of PLC Drivers

More supporting device drivers are being developed every day.

Allen Bradley DF1	LG Master K
Allen Bradley DH485	Matsushita FP (Aromat/Panasonic)
Crouzet XC03	MITSUBISHI A Series
DELTA DVP	MITSUBISHI F Series
EMERSON EC20	MITSUBISHI J2
ENTERTRON MODBUS RTU	MODICON MODBUS RTU
FACON FB	MODBUS RTU TCP/IP
Fuji NB Series	OMRON
GE FANUC SNP-X	SAIA PCD
HITACHI EH-150	Samsung SPC-10
IDEC Micro3	Sharp JW Series
IDEC OpenNET	SIEMENS S7-200
INDUSTRIAL INDEXING SYSTEMS, INC.	SIEMENS S7/300
Jetter Nano	SIMATIC T1505
Keyence KV-16DT	Telemecanique Unitelway
KOYO Direct	Toshiba T Serial
Lenze	VIGOR M Series
LG GLOFA Cnet	Yokogawa PLC Series

General Specifications

Input power	23-25 VDC, 500 mA @ 24VDC
CE	Complies with EN50081-2 and EN50082-2 standards
EMI	Complies with FCC Class A (Ferrite core required when using unshielded power supply wires)
Isolation resistance	Exceeds 50 M @ 500VDC
Vibration endurance	10 to 25 Hz (X,Y,Z direction 2G 30 minutes)
Protection structure	NEMA 4 / IP65 front panel (when mounted with gasket seal)
Temperature	Operating: 32 to 113 °F (0 to 45 °C); Storage: -13 to 158 °F (-25 to 70°C)
Operation humidity	10 to 90% RH Non Condensing
Enclosure	Plastic: Polybutylene Terephthalate (PBT) and Polycarbonate(PC)

Hardware Specification 730T/730T-E

LCD Display	5.6" TFT 256 color
Contrast Ratio	250:1
Brightness cd/m2	350
Back light	LED, MTBF 30,000 hr
Resolution pixels	320(W) x 234(H)
Viewing Angle	Top 20°; Bottom 40°; Right 50°; Left 50°;
Pixel size	0.118(W) x 0.362 (H) mm
Display area (mm)	120(W) x 90(H)
Touch panel	4 wire analog resistive type
Touch granularity	1.5mm grid
Touch Feedback	Beeper and or Graphic Indicator
Surface hardness	4H
Processor	32 bit RISC PXA255 200MHz
Flash Memory	2MB flash ROM
Compact Flash Slot	(-E Option) Used for project transfers only
System Memory	4MB DRAM
Battery Held Memory	128kB with Y2K compliant Real Time Clock/Calendar
Serial ports	1 RS-232 (Controller port), 1 RS-485 (Controller port) and 1 RS-232 485 (PC port)
Ethernet port	(-E Option) RJ-45, 8 wire (10 BaseT) TCP/IP
System diagnostic	Watch dog timer, power failure detection
Dimensions	H x W x D inches (H x W x D) mm
Bezel:	5.90 x 8.00 x 2.00 (150 x 204 x 48)
Cutout:	5.43 x 7.56 (138 x 192)
Weight	Approx. 1.9 lbs. (0.85 kg)

EasyBuilder Software Specification

Screen editor	EasyBuilder Version 2.7.0 or later (requires Windows 98 / ME / 2000 / XP)
No. of window	1 ~ 1999, limited by memory
No. of object	Up to 500 per window, limited by memory
Text strings	limited only by memory
Bitmap graphics	256 KB per graphic, limited by memory
Support PLC	Most popular PLC's
Macro scripts	Up to 256 Macro scripts per project, limited by memory

Computer requirements include at least a Pentium 90Mhz PC, 16MB RAM, 10MB available hard disk space, minimum 800x600 resolution VGA, and one available RS-232 serial port.

EasyBuilder has a complete set of drawing tools as well as the ability to import and place bitmaps. Summary of EasyBuilder Objects

Bit Lamp – Place an indicator that is bit triggered

Word Lamp – Place an indicator that is word triggered

Set Bit – Set a bit on a button press, button hold, window change, backlight activation or data entry.

Set Word – Set a word on a button press, button hold, window change, backlight activation or data entry.

Toggle Switch – Toggle a bit

MultiState Switch – Increment/Decrement a word

Function Button – Perform a system operation

Numeric Input / Display – Change/Display digital data

ASCII Input / Display – Change/Display alphanumeric data

X,Y Move Animation – Move an object via pixel coordinates

Spot Move Animation – Move an object on a predefined path

Direct Window – Popup Window on Bit status change

Indirect Window – Popup Window depending on Word's value

Alarm Display – display predefined text strings in response to bit changes

Trend Graph – Plots active data on a trend

XY Plot – Plots active data on a grid BarGraph

Meter – Display one of 4 different types of meters

Scrolling Alarm – display predefined text strings in response to bit changes

Event Display – display and log predefined text strings in response to bit or word changes

Recipe Transfer – move data to and from the PLC

PLC Controls: Change window, Backlight control, Macro Execution, Data Transfer

Dimensions

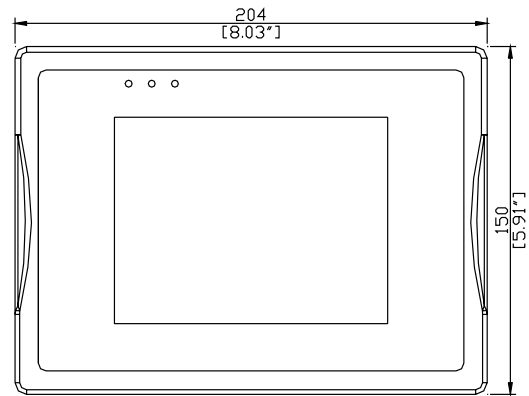

Front View

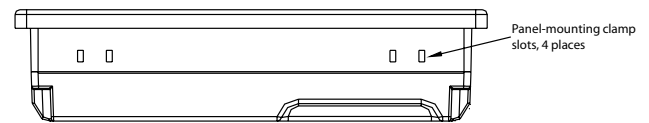

Bottom View

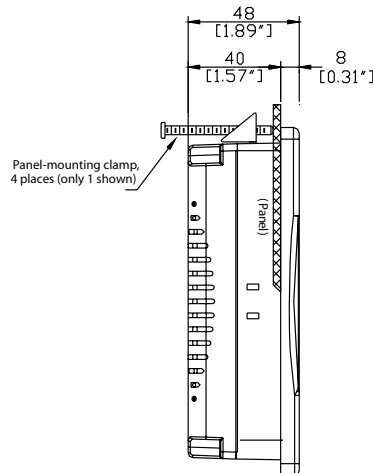

Side View

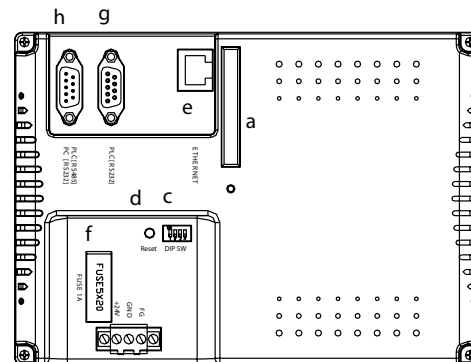

Rear View

Ordering Information:

Part Number Description

MMI-730T Graphic Interface with 5.6" Color LCD display and Touchscreen, Real Time Clock. Replaces MMI-720

MMI-730T-E Graphic Interface with 5.6" Color LCD display and Touchscreen, Real Time Clock with Ethernet and Compact Flash options. Replaces MMI-750 and MMI-750T

a. CompactFlash™ slot	e. Ethernet port
b. Power terminal	f. Fuse
c. DIP Switch	g. PLC [RS-232]
d. Reset button	h. PLC [RS-485]/PC[RS232]

MMI-COVER

5.6, 8.0, 10.4” Protective Overlays

Features

- LCD Graphic Display with Touch Panel
- Protects against scratches, grime, and fingerprints
- Chemical resistant.
- Designed to fit the MMI Touchscreen Series



Introduction

The protective sheet adds a clear protective shield to your MMI touchscreen. Each protective screen comes with a peel-off film on the front to prevent scratching and a peel-off film in the back to protect the adhesive around the perimeter.

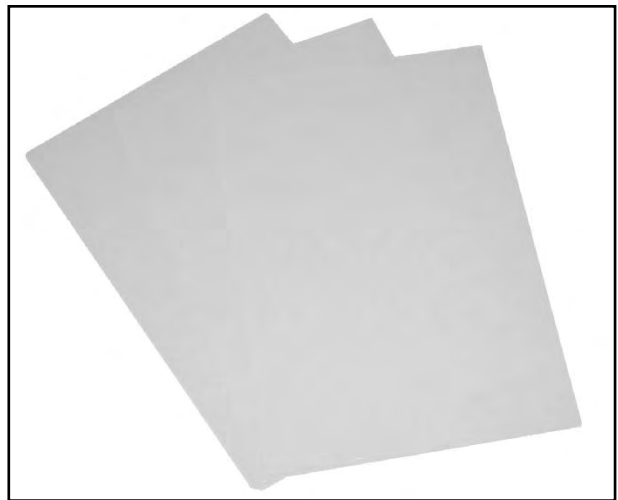

Specifications

Material: Polyester film.

Chemical resistance:

Resistant to:
Alcohols
Dilute Acids
Dilute Alkalis
Esters
Hydrocarbons
Ketones

Dimensions (W x H x D):

MMI-7XX-COVER (for MMI730T & MMI8056):
183 x 129 x 0.18mm

MMI-8XX-COVER (for MMI-850 Series & MMI8080):
219 x 164 x 0.18mm

MMI-15XX-COVER (for MMI-1500 Series & MMI8104):
294 x 217.3 x 0.18mm

Ordering Information

MMI-7XX-COVER: (for MMI730T & MMI8056)
Protective Sheet 5 sheets per package.

MMI-8XX-COVER: (for MMI-850 Series & MMI8080)
Protective Sheet 5 sheets per package.

MMI-15XX-COVER: (for MMI-1500 Series & MMI8104)
Protective Sheet 3 sheets per package.

MMI-10

Message Center

Features

- Windows™ based setup software
- Setup software can convert projects from one PLC brand to another
- 2 x 20 character, LCD or VFD display
- Small DIN size
- Multiple embedded variables per screen
- Smart cable hookup to PLC's
- RS-232 printer port
- Message capacity is limited only by memory

Description

The MMI-10 is a message center based on the powerful features found in our other MMI products. The easy to use Windows™ setup software allows users to quickly configure their units.

MESSAGES

The MMI-10 can store a large number of messages. Message numbers can range from 1 to 65500. A register called the Message Triggering Register (MTR) is defined in the PLC. The MMI-10 reads the contents of this register in every scan and the message corresponding to the number in the MTR is displayed on the MMI-10. A message can be assigned to each line on the MMI-10. Messages can scroll, flash, have minimum time for display and can be chained to other messages. They can also be designated to be printed through the serial port.



Specifications

Display	2 x 20 Char. LCD or VFD
Character Size	0.23" (5.5mm)
Memory	32k EEPROM
Set-Up	Windows™ based PC software
Programming	via RS-232
Message	via message triggering register request.
Power Supply	12-24 VDC
Operating Temperature	32° to 122° F (0° to 50° C)
Dimensions	W= 5.67", H= 2.83", D= 3.54"
Cutout	W= 5.43", H= 2.68"
Environmental	NEMA4 / IP65
Approvals	CE Certified

How To Order:

EXAMPLE: MMI10 V

Series	_____
MMI -10	
Display Type	_____
L= LCD	
V=VFD	

For PLC type refer to SMIC Cables in the Accessories Section of this catalog.

Free MMISoft setup software is included with each unit.

Accessories:

ZA9M9F - Five feet of cable with DB9 male connector and DB9 female connector.
(PC end, normally used for "AT" COM1)

ZA9M25F - Five feet of cable with DB9 male connector and DB25 female connector.
(PC end, normally used for "XT" or "AT" COM2)

MMI-40

Message Center with Four Line Display

Features

- Windows™ based setup software
- Setup software can convert projects from one PLC brand to another
- 4 x 20 character, LCD display
- Small DIN size
- Multiple embedded variables per screen
- Smart cable hookup to PLC's
- RS-232 printer port
- Message capacity is limited only by memory

Description

The MMI-40 is a message center based on the powerful features found in our other MMI products. The easy to use Windows™ setup software allows users to quickly configure their units.

MESSAGES

The MMI-40 can store a large number of messages. Message numbers can range from 1 to 65500. A register called the Message Triggering Register (MTR) is defined in the PLC. The MMI-40 reads the contents of this register in every scan and the message corresponding to the number in the MTR is displayed on the MMI-40. A message can be assigned to each line on the MMI-40. Messages can scroll, flash, have minimum time for display and can be chained to other messages. They can also be designated to be printed through the serial port.



Specifications

Display	4 x 20 Char. LCD
Character Size	0.23" (5.5mm)
Memory	32k EEPROM
Set-Up	Windows™ based PC software
Programming	via RS-232
Message	via message triggering register request.
Power Supply	12-24 VDC
Operating Temperature	32° to 122° F (0° to 50° C)
Dimensions	W= 5.67", H= 2.83", D= 3.54"
Cutout	W= 5.43", H= 2.68"
Environmental	NEMA4 / IP65
Approvals	CE Certified

How To Order:

EXAMPLE: MMI40

L

Series

MMI -40

Display Type

L= LCD

For PLC type refer to SMIC Cables in the Accessories Section of this catalog.

Free MMISoft setup software is included with each unit.

Accessories:

ZA9M9F - Five feet of cable with DB9 male connector and DB9 female connector.
(PC end, normally used for "AT" COM1)

ZA9M25F - Five feet of cable with DB9 male connector and DB25 female connector.
(PC end, normally used for "XT" or "AT" COM2)

MMI-100

Message Center with Function Keys

Features

- Windows™ based setup software
- Setup software can convert projects from one PLC brand to another
- 2 x 20 character, LCD or VFD display
- 8-30 VDC power
- Small DIN size
- 8 Programmable function keys
- Multiple embedded variables per screen
- Smart cable hookup to PLC's
- Serial interface for PLC connection and programming setup.
- RS-232 printer port
- Message capacity is limited only by memory



Description

The MMI-100 provides a powerful yet cost effective Programmable Logic Controller (PLC) interface where space requirements are critical and cost is important. It communicates directly with the PLC through the programming port so that I/O can be used for what it is intended. In addition, the MMI-100 provides a serial output port to support a printer or additional slave device.

Function Keys

The 8 user definable keys make machine interfacing very simple. The function keys are legendable and can be used for various PLC interactive applications including:

- Turn ON/OFF internal contacts
- Hold On/OFF contact while key is pressed
- Toggle status of contact
- Download a constant to PLC register
- Trigger a message

Data Entry

Special messages can be used to load values into the PLC. The register that is to be modified would be defined in the message. The user can also embed the data within this message making it very user friendly. A bit/coil can also be edited in an interactive manner using a similar special message.

MESSAGES

The MMI-100 can store a large number of messages. A register called the Message Triggering Register (MTR) is defined in the PLC. The MMI-100 reads the contents of this register in every scan and the message corresponding to the number in the MTR is displayed on the MMI-100. A message can be assigned to each line on the MMI-100. Messages can scroll, flash, have minimum time for display and can be chained to other messages. They can also be designated to be printed through the serial port.

Specifications

Display	2 x 20 Char. LCD or VFD
Character Size	0.23" (5.5mm)
Memory	32k EEPROM
Set-Up	Windows™ based PC software (order separately)
Programming	via RS-232
Message Request	via message triggering register or function key
Function Keys	8 user programmable function keys
Power Supply	12-24 VDC
Operating Temperature	32° to 122° F (0° to 50° C)
Dimensions	W= 5.67", H= 2.83", D= 3.54"
Cutout	W= 5.43", H= 2.68"
Environmental	NEMA4 / IP65
Approvals	CE Certified

MMI Setup Software Information

The Windows® based MMI setup software is a convenient way to setup this PLC Interface Product.



Our software makes Function Key setup a snap! Create, Edit and View messages with Point & Click Ease!

How To Order:

EXAMPLE: **MMI100** **V**

Series **MMI -100**

Display Type
L= LCD
V=VFD

For PLC Type

Use Smart cable part number as indicated below. Also refer to SMC Cables in the Accessories Section of this catalog.

The MMI-100 will not operate without a cable and software.

EXAMPLE: **SMIC- GE90- 05**

Series

PLC Type

AB500	AB SLC500 types with DH485 port
ABDF1	AB SLC500 5/03, 5/04 with DF1 port
ABMICRO	AB MicroLogix only
ABAIC	For use with AB AIC Modules
ARO	All Aromat FP1 Series
FUJI	Fuji Flex Series NB, NJ and NS
GE90	All GE 90 Series SNP Port
IDECM1	Idec M1 and FA2J
IDECM3	Idec Micro3 Series
IDECM3C	Idec Micro3C Series
K205	Koyo DL230, DL240, DL250
K305	Siemens Simatic 335, Koyo 340
K405	Siemens Simatic 425, 435, Koyo 440
KEY	Keyence KV 10,16,24,40 & 80, KV300
MOD	Modicon Micro 84; 884; 984; Open Modbus & J-Bus
MODMICRO	Modicon Micro 984
MITFX	Mitsubishi FX Series
MITFXO	Mitsubishi FXo only
OMCK25	Omron C Series, (Host link modules)
OMCH9	Omron CH Series
OMCQM	Omron CQM1 Series
SIS5	Siemens S5 Series, 95, 100, 102, 103, 115
SIS7	Siemens S7-200 Series
TSBT1	Toshiba T1 only
TSBT2	Toshiba T2 and T3
TSX07	Telemecanique TSX 07 (nano), TSX 37
TSX17	Telemecanique TSX 17
TSX47	Telemecanique TSX 47-40, TSX 47-20

Cable Length

05 = 5 feet

Accessories:

ZA9M9F - Five feet of cable with DB9 male connector and DB9 female connector.
(PC end, normally used for "AT" COM1)

ZA9M25F - Five feet of cable with DB9 male connector and DB25 female connector.
(PC end, normally used for "XT" or "AT" COM2)

Free MMISoft setup software is included with each unit.

MMI-110

Message Center with Function Keys & Data Access

Features

- Windows™ based setup software
- Setup software can convert projects from one PLC brand to another
- 2 x 20 character, LCD or VFD display
- Small DIN size
- 8 Programmable function keys
- Multiple embedded variables per screen
- Smart cable hookup to PLC's
- Numeric keys for easy data entry
- RS-232 printer port
- Message capacity is limited only by memory
- Operator controlled scrolling through linked messages

Description

The MMI-110 provides all of the powerful features found in the MMI-100 with the addition of four keys which allow for easy data entry. The easy to use Windows™ setup software allows users to quickly configure their units.

Function Keys

The 8 user definable keys make machine interfacing very simple. The function keys are legible and can be used for various PLC interactive applications including:

- Turn ON/OFF internal contacts
- Hold On/OFF contact while key is pressed
- Toggle status of contact
- Download a constant to PLC register
- Trigger a message for data entry

Data Entry

By pressing the CLR/DATA key, the keys become activated for entering numerical values. Through the use of 0-9 keys, an operator can easily change values of PLC registers. Bit/coil status can also be edited in an interactive manner using special messages.



MESSAGES

The MMI-110 can store a large number of messages. Message numbers can range from 1 to 65500. A register called the Message Triggering Register (MTR) is defined in the PLC. The MMI-110 reads the contents of this register in every scan and the message corresponding to the number in the MTR is displayed on the MMI-110.

A message can be assigned to each line on the MMI-110. Messages can scroll, flash, have minimum time for display and can be chained to other messages. They can also be designated to be printed through the serial port. Messages can be linked together to make menus or lists which the operator can scroll through using the up and down arrow keys.

Specifications

Display	2 x 20 Char. LCD or VFD
Character Size	0.23" (5.5mm)
Memory	32k EEPROM
Set-Up	Windows™ based PC software (order separately)
Programming	via RS-232
Message Request	via message triggering register or function key
Function Keys	8 user programmable function keys
Power Supply	12-24 VDC
Operating Temperature	32° to 122° F (0° to 50° C)
Dimensions	W= 5.67", H= 2.83", D= 3.54"
Cutout	W= 5.43", H= 2.68"
Environmental	NEMA4 / IP65
Approvals	CE Certified

MMI Setup Software Information

The Windows® based MMI setup software is a convenient way to setup this PLC Interface Product.



Our software makes Function Key setup a snap! Create, Edit and View messages with Point & Click Ease!

How To Order:

EXAMPLE: **MMI110** **V**

Series **MMI-110**

Display Type
L= LCD
V=VFD

For PLC Type

Use Smart cable part number as indicated below. Also refer to SMC Cables in the Accessories Section of this catalog.

The MMI-110 will not operate without a cable and software.

EXAMPLE: **SMIC- GE90- 05**

Series

PLC Type

AB500	AB SLC500 types with DH485 port
ABDF1	AB SLC500 5/03, 5/04 with DF1 port
ABMICRO	AB MicroLogix only
ABAIC	For use with AB AIC Modules
ARO	All Aromat FP1 Series
FUJI	Fuji Flex Series NB, NJ and NS
GE90	All GE 90 Series SNP Port
IDECM1	Idec M1 and FA2J
IDECM3	Idec Micro3 Series
IDECM3C	Idec Micro3C Series
K205	Koyo DL230, DL240, DL250
K305	Siemens Simatic 335, Koyo 340
K405	Siemens Simatic 425, 435, Koyo 440
KEY	Keyence KV 10,16,24,40 & 80, KV300
MOD	Modicon Micro 84; 884; 984; Open Modbus & J-Bus
MODMICRO	Modicon Micro 984
MITFX	Mitsubishi FX Series
MITFXO	Mitsubishi FXo only
OMCK25	Omron C Series, (Host link modules)
OMCH9	Omron CH Series
OMCQM	Omron CQM1 Series
SIS5	Siemens S5 Series, 95, 100, 102, 103, 115
SIS7	Siemens S7-200 Series
TSBT1	Toshiba T1 only
TSBT2	Toshiba T2 and T3
TSX07	Telemecanique TSX 07 (nano), TSX 37
TSX17	Telemecanique TSX 17
TSX47	Telemecanique TSX 47-40, TSX 47-20

Cable Length

05 = 5 feet

Accessories:

ZA9M9F - Five feet of cable with DB9 male connector and DB9 female connector.
(PC end, normally used for "AT" COM1)

ZA9M25F - Five feet of cable with DB9 male connector and DB25 female connector.
(PC end, normally used for "XT" or "AT" COM2)

Free MMISoft setup software is included with each unit.

MMI-140

Message Center with Data Access & Four Line Display

Features

- Windows™ based setup software
- Setup software can convert projects from one PLC brand to another
- 4 x 20 character, LCD display
- Small DIN size
- 8 Programmable function keys
- Multiple embedded variables per screen
- Smart cable hookup to PLC's
- Numeric keys for easy data entry

Description

The MMI-140 provides all of the powerful features found in the MMI-110. Its multifunction keypad allows for easy data entry. The easy to use Windows™ setup software allows users to quickly configure their units.

Function Keys

The 8 user definable keys make machine interfacing very simple. The function keys are legendable and can be used for various PLC interactive applications including:

- Turn ON/OFF internal contacts
- Hold On/OFF contact while key is pressed
- Toggle status of contact
- Download a constant to PLC register
- Trigger a message for data entry

Data Entry

By pressing the CLR/DATA key, the keys become activated for entering numerical values. Through the use of 0-9 keys, an operator can easily change values of PLC registers. Bit/coil status can also be edited in an interactive manner using special messages.

Messages

The MMI-140 can store a large number of messages. Message numbers can range from 1 to 65500. A register called the Message Triggering Register (MTR) is defined in the PLC. The MMI-140 reads the contents of this register in every scan and the message corresponding to the number in the MTR is displayed on the MMI-140. A message can be assigned to the full, upper or lower part of the MMI-140 display. Messages can scroll, flash, have minimum time for display and can be chained to other messages. They can also be designated to be printed through the serial port. Messages can be linked together to make menus or lists which the operator can scroll through using the up and down arrow keys.



- RS-232 printer port
- Message capacity is limited only by memory
- Operator controlled scrolling through linked messages

Specifications	
Display	4 x 20 Char. LCD
Character Size	0.23" (5.5mm)
Memory	32k EEPROM
Set-Up	Windows™ based PC software
Programming	via RS-232
Message	via message triggering register request or function key.
Function Keys	8 user programmable F-keys
Power Supply	12-24 VDC
Operating Temperature	32° to 122° F (0° to 50° C)
Dimensions	W= 5.67", H= 2.83", D= 3.54"
Cutout	W= 5.43", H= 2.68"
Environmental	NEMA4 / IP65
Approvals	CE Certified

How To Order:

EXAMPLE: MMI140 L

Series	MMI -140
Display Type	L = LCD

For PLC type refer to SMIC Cables in the Accessories Section of this catalog.

Free MMISoft setup software is included with each unit.

Accessories:

- ZA9M9F** - Five feet of cable with DB9 male connector and DB9 female connector. (PC end, normally used for "AT" COM1)
- ZA9M25F** - Five feet of cable with DB9 male connector and DB25 female connector. (PC end, normally used for "XT" or "AT" COM2)

MMI-220

Features

- 2 Line by 20 Character Display
- Bar Graph Capable
- Connects to The PLC's Programming Port
- The Number of Messages To View Machine / Process Status is Limited Only by Memory
- Recipe Management with Retentive Internal Registers
- User Friendly Prompts to Change Data and Presets
- 20 Programmable (40 using shift key) Push-Buttons and LED's
- Setup software can convert projects from one PLC brand to another

DESCRIPTION

The new MMI-220 from KEP is a simple, easy to use, cost effective interface. It communicates with the PLC directly through the programming port. Expensive I/O, interface ladder logic or hard wiring are no longer needed.

FUNCTION KEYS

The MMI-220 has 20 (40 using shift key) user definable keys which can be used as push buttons or as selector switches. Each key can be defined to do one of the following functions:

- Turn specified bits ON or OFF
- Hold Specified bits ON or OFF while the key is pressed
- Toggle the status of a specified bit (like a selector switch).
- Edit or download constants and recipe values to the PLC.
- Trigger a message for data entry.
- Trigger a message chain or linked list useful for machine setup etc..

Access to Function keys can be password protected.

ANNUNCIATOR LEDS

The MMI-220 has 20 user definable LEDs for the purpose of annunciation The LEDs are mapped to a user definable register in the PLC. A beeper is also provided for annunciation.

ENTERING DATA -- The NUM key is used for changing bit, register, preset and accumulator values.

A new value may be entered into a register if:

- a) The register is not Password protected; or
- b) The Password is assigned a value of 0000.

Programmable Push Button and Message Panel



- Message Chaining and Linking
- Serial Printer Port, Beeper and Open Collector Output

Press the NUM key to change a bit status, register, preset or accumulator value while it is being displayed. You will notice that the last digit of the displayed value or status is flashing. This indicates that the unit is ready to accept a new value. Use the CLR key and Number keys to change the flashing value. Press ENT to accept the value.

If the register or bit is assigned write protection the unit will prompt the operator for the Write Password when the NUM button is pressed. The password is entered the same way that new data is entered as described above.

MESSAGES

The MMI-220 can store a large number of messages. A register called the Message Triggering Register (MTR) is defined in the PLC. The MMI-220 reads the contents of this register in every scan and the message corresponding to the number in the MTR is displayed on the MMI-220. A message can be assigned to each line on the MMI-220. Messages can scroll, flash, have minimum time for display and can be chained or linked to other messages. They can also be designated to be printed through the serial port.

A list of messages can be defined (called linked messages) allowing the operator to scroll through this list of messages simply by pressing the NEXT key.

Messages can have PLC data embedded in Decimal, Hex, Binary or BCD formats. They can also have text dependent on a bit status or can have data displayed as a bar graph making the unit very user friendly.

SETUP

The MMI-220 is setup on an IBM PC using a Windows™ based setup software package. Simply point and click and you are ready to go!

SPECIFICATIONS

Power	12 to 24 VDC, 6W Maximum
Display	LCD Backlit Liquid Crystal Display; 2 lines; 20 characters per line; character height is 0.2" VFD Vacuum Fluorescent Display; 2 lines; 20 characters per line; character height is 0.2"
Bezel	NEMA 4 / IP65 rated membrane keypad
Temperature	Operating: - 0 to 50 degrees C Storage: -40 to 90 degrees C
Humidity	10% to 90% (Non condensing)
Size	8" W x 6" H x 1.75" D (203.2 mm x 152.4 mm x 44.45 mm)
Panel Cutout:	7.1"W x 5.1"H (180.3 mmWx 152.4 mm H)
Communication	Using the programming or the standard communication port of the PLC
Memory	8k EEPROM expandable to 32k
Open Collector O/P	24 Volts at 100 mA maximum
Immunity to ESD	8 kV Air, 6 kV Contact as per IEC801-2
Immunity to Transients	2 kV as per IEC801-4 2 kV 1 us Impulse Noise
Radiated Susceptibility	10 Volts/meter as per IEC801-3
Emissions	EN5501,1 CISPR A
Approvals	CE Pending

Dimensions:

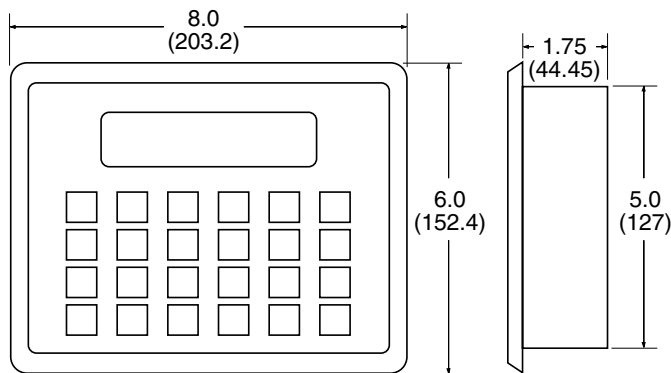

PANEL CUTOUT: 7.1 (180.3) X 5.1 (129.5)

All Dimensions in inches (mm)

MMI Setup Software Information

The Windows® based MMI setup software is a convenient way to setup this PLC Interface Product.



How To Order:

EXAMPLE: **MMI220** **V** **A**

Series _____
MMI-220

Display Type _____
L= LCD
V=VFD

Options (add to end of part number) _____
32 = 32K of storage
A = 115 VAC Power
B = 230 VAC Power

For PLC Type

Use Smart cable part number as indicated below. Also refer to SMIC Cables in the Accessories Section of this catalog. The MMI-220 will not operate without a smart cable and software.

EXAMPLE: **SMIC-** **GE90-** **05**

Series _____

PLC Type _____

AB500	AB SLC500 types with DH485 port
ABDF1	AB SLC500 5/03, 5/04 with DF1 port
ABMICRO	AB MicroLogix only
ABAIC	For use with AB AIC Modules
ARO	All Aromat FP1 Series
FUJI	Fuji Flex Series NB, NJ and NS
GE90	All GE 90 Series SNP Port
IDECM1	Idec M1 and FA2J
IDECM3	Idec Micro3 Series
IDECM3C	Idec Micro3C Series
K205	Koyo DL230, DL240, DL250
K305	Siemens Simatic 335, Koyo 340
K405	Siemens Simatic 425, 435, Koyo 440
KEY	Keyence KV 10,16,24,40 & 80, KV300
MOD	Modicon Micro 84; 884; 984; Open Modbus & J-Bus
MODMICRO	Modicon Micro 984
MITFX	Mitsubishi FX Series
MITFXO	Mitsubishi FXo only
OMCK25	Omron C Series, (Host link modules)
OMCH9	Omron CH Series
OMCQM	Omron CQM1 Series
SIS5	Siemens S5 Series, 95, 100, 102, 103, 115
SIS7	Siemens S7-200 Series
TSBT1	Toshiba T1 only
TSBT2	Toshiba T2 and T3
TSX07	Telemecanique TSX 07 (nano), TSX 37
TSX17	Telemecanique TSX 17
TSX47	Telemecanique TSX 47-40, TSX 47-20

Cable Length _____
05 = 5 feet

Accessories:

ZA9M9F - Five feet of cable with DB9 male connector and DB9 female connector.
(PC end, normally used for "AT" COM1)

ZA9M25F - Five feet of cable with DB9 male connector and DB25 female connector.
(PC end, normally used for "XT" or "AT" COM2)

Free MMISoft setup software is included with each unit.

Our software makes Function Key setup a snap!
Create, Edit and View messages with Point & Click Ease!

MMI-240

Features

- 4 Line x 20 Character Display
- Bar Graph Capable
- Connects to The PLC'S Programming Port
- The Number of Messages To View Machine / Process Status is Limited Only by Memory
- Recipe Management with Retentive Internal Registers
- User Friendly Prompts to Change Data and Presets
- 20 Programmable (40 using shift key) Push-Buttons and LED's
- Setup software can convert projects from one PLC brand to another

DESCRIPTION

The new MMI-240 from KEP is a great addition to our line of operator interface products. Featuring a 4 line, 20 character LCD or VFD display, the MMI-240 allows the operator to view many parameters at one time. The MMI-240 communicates with the PLC through the PLC's programming port.

FUNCTION KEYS

The MMI-240 has 20 (40 using shift key) user definable keys which can be defined to do one of the following functions:

- Turn specified bits ON or OFF.
- Hold specified bits ON or OFF while the key is pressed.
- Toggle the status of a specified bit (like a selector switch).
- Edit or download constants and recipe values to the PLC.
- Trigger a message for data entry.
- Trigger a message chain or linked list useful for machine setup etc..

Access to Function keys, can be password protected.

ANNUNCIATOR LEDs

The MMI-240 has 20 user definable LEDs for the purpose of annunciation. The LEDs are mapped to a register in the PLC. A Beeper is provided for annunciation.

ENTERING DATA -- The NUM key is used for changing bit, register, preset and accumulator values.

A new value may be entered into a register if:

- a) The register is not Password protected; or
- b) The Password is assigned a value of 0000.

Programmable Push Button and Message Panel

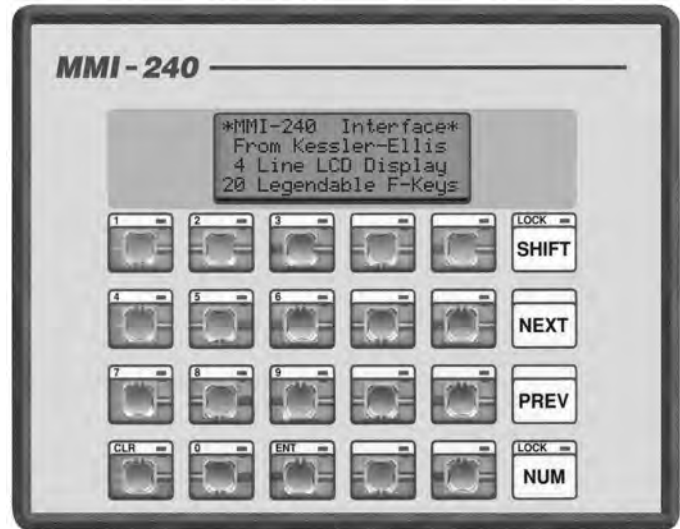

- Message Chaining and Linking
- Serial Printer Port, Beeper and Open Collector Output

Press the NUM key to change a bit status, register, preset or accumulator value while it is being displayed. You will notice that the last digit of the displayed value or status is flashing. This indicates that the unit is ready to accept a new value. Use the CLR key and Number keys to change the flashing value. Press ENT to accept the value.

If the register or bit is assigned write protection the unit will prompt the operator for the Write Password when the NUM button is pressed. The password is entered the same way that new data is entered as described above.

MESSAGES

The MMI-240 has a message capacity limited only by memory. A register called the Message Triggering Register (MTR) is defined in the PLC. The MMI-240 reads the contents of this register during every scan. The message corresponding to the number in the MTR is displayed on the MMI-240. A message can be assigned to the upper or lower lines on the MMI-240. Messages can scroll, flash, be displayed for a minimum time, and can be chained or linked to other messages. They can also be directed to print through the serial port.

A list of messages can be defined (called linked messages) and the operator can scroll through this list of messages simply by pressing the NEXT key.

Messages can have PLC data embedded in Decimal, Hex, Binary or BCD format. They can have text dependent on a bit status or can have data displayed as a bar graph making the unit very powerful.

SETUP

The MMI-240 is setup by a PC using MMISOFT, a Windows™ based setup software package. Simply point and click and you are ready to go!

SPECIFICATIONS

Power	12 to 24 VDC, 6W Maximum
Display	LCD Backlit Liquid Crystal Display; 4 lines; 20 characters per line; character height is 0.2" VFD Vacuum Fluorescent Display; 4 lines; 20 characters per line; character height is 0.2"
Bezel	NEMA 4 / IP65 rated membrane keypad
Temperature	Operating: - 0 to 50 degrees C Storage: -40 to 90 degrees C
Humidity	10% to 90% (Non condensing)
Size	8" W x 6" H x 1.75" D (203.2 mm x 152.4 mm x 44.45 mm)
Panel Cutout:	7.1"W x 5.1"H (180.3 mmWx 152.4 mm H)
Communication	Using the programming or the standard communication port of the PLC
Memory	32k EEPROM
Open Collector O/P	24 Volts at 100 mA maximum
Immunity to ESD	8 kV Air, 6 kV Contact as per IEC801-2
Immunity to Transients	2 kV as per IEC801-4 2 kV 1 us Impulse Noise
Radiated Susceptibility	10 Volts/meter as per IEC801-3
Emissions	EN5501,1 CISPR A
Approvals	CE Pending

Dimensions:

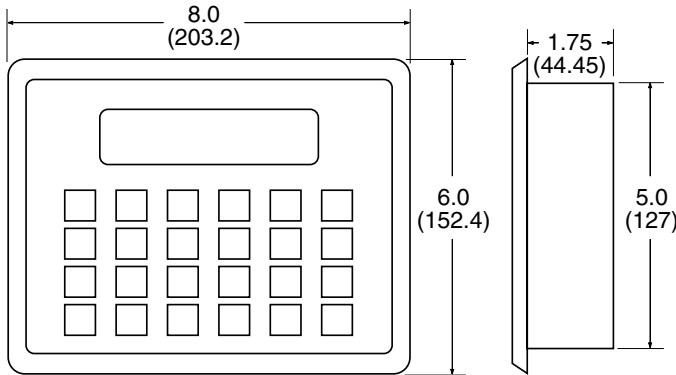

PANEL CUTOUT: 7.1 (180.3) X 5.1 (129.5)

All Dimensions in inches (mm)

MMI Setup Software Information

The Windows® based MMI setup software is a convenient way to setup this PLC Interface Product.



How To Order:

EXAMPLE: **MMI240** **V** **A**

Series _____
 MMI-240

Display Type _____
 L= LCD
 V=VFD

Options (add to end of part number) _____
 A = 115 VAC Power
 B = 230 VAC Power

For PLC Type

Use Smart cable part number as indicated below. Also refer to SMIC Cables in the Accessories Section of this catalog.
The MMI-100 will not operate without a cable and software.

EXAMPLE: **SMIC-** **GE90-** **05**

Series _____

PLC Type _____

- AB500** **AB SLC500 types with DH485 port**
- ABDF1** **AB SLC500 5/03, 5/04 with DF1 port**
- ABMICRO** **AB MicroLogix only**
- ABAIC** **For use with AB AIC Modules**
- ARO** **All Aromat FP1 Series**
- FUJI** **Fuji Flex Series NB, NJ and NS**
- GE90** **All GE 90 Series SNP Port**
- IDECM1** **Idec M1 and FA2J**
- IDECM3** **Idec Micro3 Series**
- IDECM3C** **Idec Micro3C Series**
- K205** **Koyo DL230, DL240, DL250**
- K305** **Siemens Simatic 335, Koyo 340**
- K405** **Siemens Simatic 425, 435, Koyo 440**
- KEY** **Keyence KV 10,16,24,40 & 80, KV300**
- MOD** **Modicon Micro 84; 884; 984; Open Modbus & J-Bus**
- MODMICRO** **Modicon Micro 984**
- MITFX** **Mitsubishi FX Series**
- MITFXO** **Mitsubishi FXo only**
- OMCK25** **Omron C Series, (Host link modules)**
- OMCH9** **Omron CH Series**
- OMCQM** **Omron CQM1 Series**
- SIS5** **Siemens S5 Series, 95, 100, 102, 103, 115**
- SIS7** **Siemens S7-200 Series**
- TSBT1** **Toshiba T1 only**
- TSBT2** **Toshiba T2 and T3**
- TSX07** **Telemecanique TSX 07 (nano), TSX 37**
- TSX17** **Telemecanique TSX 17**
- TSX47** **Telemecanique TSX 47-40, TSX 47-20**

Cable Length _____
05 = 5 feet

Accessories:

ZA9M9F - Five feet of cable with DB9 male connector and DB9 female connector.
(PC end, normally used for "AT" COM1)

ZA9M25F - Five feet of cable with DB9 male connector and DB25 female connector.
(PC end, normally used for "XT" or "AT" COM2)

Free MMISoft setup software is included with each unit.

Our software makes Function Key setup a snap!
Create, Edit and View messages with Point & Click Ease!

FPM Series

Industrial Flat Panel Touch-Screen Monitors

Features:

- Mounting Bezel is Sealed to NEMA 4/12
- Screen Setup is Handled Through an Easy-To-Use Rear-Mounted Membrane Keypad (tamperproof)
- Bezel is Finished With a Tough Baked-On Powder Coat Resistant to Scratches and Most Chemicals
- Compatible With Standard Computer Video Cards
- All Video Settings are Stored in Non-Volatile Memory and Retained During Power Loss
- Multi-Frequency Capability and Internal Scaling Engine Provide Sharp Full Screen Display of Standard PC Video Display Signals
- High Quality LCD Suitable for Harsh Lighting Conditions and Off-Angle Viewing
- Displays are Fitted With High Resolution Analog Resistive Touch Screen, Available Either as a Serial RS-232 Interface or PC Bus Card
- Touch Screen Provides Mouse Emulation, Supporting Click, Double Click, and Click and Drag...With Right Click Functionality!

Description:

Monitors for industrial computers have changed. Those big, clunky boxes are being replaced by slim-profile versions. These screens not only free up valuable benchtop or floor space, they also enhance the company's image with their leaner and cleaner high tech look. Kessler-Ellis Products offers a range of 7 different sizes to fit any space requirement — from a mini 6.4" up to a huge 20". These touch-screens are ruggedly constructed with a chassis of 16-gauge stainless steel, for NEMA-rated performance in harsh industrial environments. Operating temperature range is from 0 to 50° C and humidity levels of up to 95%. All models can be customized cosmetically to user requirements, including color match-ups and inclusion of company logos on mounting bezels.



- Hinged Rear Panel for Easy Access During Service
- Stainless Steel Corrosion Resistance Chassis
- Bezel is Milled from .250"-thick 6061 Aluminum Plate.
- Wide Ranging (90-246 VAC) Auto Switching Industrial Grade Power Supplies.

Ordering Information

<u>Part Number</u>	<u>Description</u>
FPM-64T	6.4" TFT Display with Touch Screen
FPM-104T	10.4" TFT Display with Touch Screen
FPM-120T	12.1" TFT Display with Touch Screen
FPM-150T	15.1" TFT Display with Touch Screen
FPM-170T	17.1" TFT Display with Touch Screen
FPM-180T	18.1" TFT Display with Touch Screen

The above products include VGA cable, DB9 cable for touchscreen, power cable, and CD with ELO touchscreen driver. These displays all feature a heavy black power coated aluminum bezel and premium high brightness and high viewing angle TFT display panels. Mounting is by means of studs on the back of the bezel, nuts included.

GENERAL SPECIFICATIONS							
	FPM-64 / 64T 6.4" Display	FPM-104 / 104T 10.4" Display	FPM-120 / 120T 12.1" Display	FPM-140 / 140T 14" Display	FPM-150 / 150T 15" Display	FPM-180 / 180T 18" Display	FPM-200 / 200T 20.1" Display
LIQUID CRYSTAL DISPLAY (LCD)							
Display Size/Type	6.4" Diagonal/TFT Active Matrix	10.4" Diagonal/TFT Active Matrix	12.1" Diagonal/TFT Active Matrix	14" Diagonal/TFT Matrix	15.1" Diagonal	18.1" Diagonal	20.1" Diagonal/TFT Active Matrix
Active Area	5.14" (h) x 3.82" (v)	8.31" (h) x 6.25" (v)	9.69" (h) x 7.25" (v)	11.19" (h) x 8.39" (v)	11.97" (h) x 8.98" (v)	14.135"(h) x 11.310"(v)	15.72" (h) x 12.58" (v)
Pixel Format	640(h) x 480(v)		800(h) x 600(v)	640(h) x 480(v) 800(h) x 600(v) 1024(h) x 768(v)		640(h) x 480(v) 800(h) x 600(v) 1024(h) x 768(v) 1280(h) x 1024(v)	
Brightness	300 Nits Typical	400 Nits Typical	300 Nits Typical	200+ Nits Typical	200 Nits Typical		150 Nits Typical
Contrast Ratio	100:1	300:1	200:1	150:1	>150:1	300:1	150:1
Viewing Angle (horiz.)	70/70 Deg.	60/60 Deg.		70/70 Deg.			80/80 Deg.
Viewing Angle (Vert.)	70/40 Deg.	45/55 Deg.	50/40 Deg.	70/70 Deg.	60/60 Deg.		80/80 Deg.
Back Light Life	50,000 Hours (half life)						
Colors Supported	256,000				16 Million with color enhancement on (Standard)	16 Million with color enhancement (standard controller function)	16 Million (full color analog LCD)
MECHANICAL CONSTRUCTION							
Bezel Outside Dim.	9.5" (h) x 7.0" (v)	13.13" (h) x 11.08" (v)	15" (h) x 12.5" (v)	16.5" (h) x 13.64" (v)	17.564"(h) x 14.563"(v)	18.927"(h) x 14.563"(v)	21.5" (h) x 18.3" (v)
Bezel Material	.250" 6061 Aluminum						
Bezel Finish	Black Textured Powder Coat						
Front End Const.	NEMA 4/12						
Chassis Depth (Behind Cabinet Door)	2.125"	1.125"	4.125"				
Chassis Construction	.16 Ga. Stainless Steel						
ENVIRONMENTAL							
Operating Temp.	0-50° C						
Storage Temp	0-60° C						
Operating Humidity	10-95% Non Condensing						
Storage Humidity	10-95% Non Condensing						
ELECTRICAL							
Input Voltage	12 VDC Nominal		90-264 VAC Auto Switching				
Input Wattage	25 Watts Typical		35 Watts Typical			50 Watts Typical	60 Watts Typical (75 Watt Power Supply)
TOUCH SCREEN							
Analog Resistive	5 Wire						
Touch Screen Res.	400 ppi						
Screen Finish	Anti Reflective						
Chemical Resistance	Acetone, MEK, Mineral spirits, Isopropyl alcohol, Methylene chloride						
Estimated Life	>35 Million touches in one location						
Computer Interface	Serial RS-232 (Standard) PC-Bus (optional)						
Electrostatic Protection	IEC-801-2						

INFILINK-HMI

Industrial Automation Software

Features

- Free Design Mode: Only pay to unlock run-mode copies
- OPC Client Functionality
- E-mail and Web Enabled: Send e-mail and View tag data over the Internet
- Historical Trending, Alarming, Data Logging included in base price
- Email and Web Enabling included in base price
- No yearly "maintenance" or "support" fees

New Features for Infilink 5.0.9:

- New Timer Objects in Project Properties.
- Message Box function in the Project Explorer.
- The Angular Gauge now supports labeling either inside or outside the tick marks.
- Embedded Windows Explorer lets you set the URL from an Infilink-HMI tag and use this to view websites, open documents or view IP video cameras that are monitoring equipment.
- Vertical Trending Display lets you scroll in either direction and individually scale the pens on vertical or horizontal plane.
- Project explorer. Contains Wizards, Animations, Project, Drag and Drop Tags
- Multi line text object.
- List box and Combo box objects.
- "Flush alarm log" menu item in run mode added. Equivalent script command "SysCmd.FlushAlarmLogger" added.
- Animation Expression can now be set for Linear gauge and Angular gauge objects instead of just tag names.
- Max OPC update rate changed from 60000 ms to one day.
- Run mode data entry onscreen keypads made resizable. Resizing these onscreen keypads will resize internal buttons proportionately. The size of the keypad is remembered when "Ok" button is pressed. Onscreen keypads affected by this modification: 1. Boolean entry keypad. 2. String entry keypad (English and French). 3. Numeric data entry keypad.
- Lock screen resolution check box added in "Project properties" dialog. Automatic scaling of graphic objects (on detecting screen resolution change) can be disabled by checking this box.
- XYPlot object added.

Description:

Infilink-HMI is a full featured solution at an affordable price. It is ideal for the small PLC user with its easy setup and run time price half that of competitive products. Machine builders and users want the benefits of a Windows based package, but are held back by the premium prices demanded by many vendors. Infilink-HMI changes all of that with the truly affordable HMI, Infilink-HMI.

Free Development System Buy Only the Runtimes You Need

Infilink-HMI now offers our complete development system for free. When you download the latest version of Infilink-HMI (5.0.0 or higher) from our web site you have a complete development system. There's no limitation on the tag count. The provided runtime has a one hour expiration time. When used in combination with a demo version of our 32 bit OPC servers, you have a complete HMI system that can be used by every developer in your organization without spending a dime.

Email Capable

Infilink-HMI can send email messages based on alarm conditions. This can be a regular email message, or it could be sent to a technician's alphanumeric pager.



Scheduler

Infilink-HMI now includes a built in scheduler. Events can take place or tag data can be changed based on time, date, day of week, or holiday. New events can be entered by the operator in Run mode through the calendar interface.

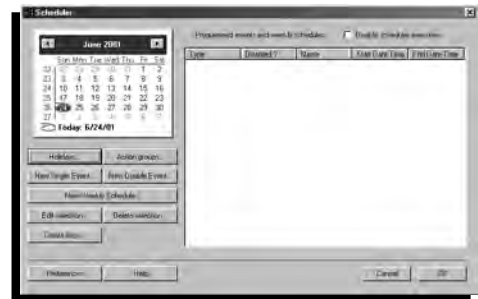

Infilink-HMI Communicates Using KEPServerEX

- One free driver included with Infilink-HMI purchase.
- OPC and DDE supported.
- Over 100 drivers available.
- Support for various fieldbus networks including Ethernet TCP/IP and DeviceNet.

Web Enabled

Use the internet and our In-fiviewer utility to view tag data. This is an especially powerful troubleshooting feature when combined with email going to an alphanumeric pager. Infilink can notify technical personnel of a problem via email, and give them the ability to obtain additional application information over the internet.



Graphic Objects and Editing Features

Infilink-HMI provides a powerful set of graphic primitives and editing features allowing you to easily depict your application's displays. All of these functions are available from our toolbox. Store your objects in libraries for reuse later or use the 2000+ library objects available with Infilink-HMI to speed your development.

Professional Library Objects

Infilink-HMI includes over 2000 professionally drawn library objects licensed from Reichard Software, famous for their Symbol Factory product. Additionally, our libraries also contain hundreds of pre-animated objects such as buttons, meters, displays, and sliders to a name few. These pre-animated objects can quickly be added to your application using the new Reassign Tags function. Drag and Drop objects out of the library into your application.

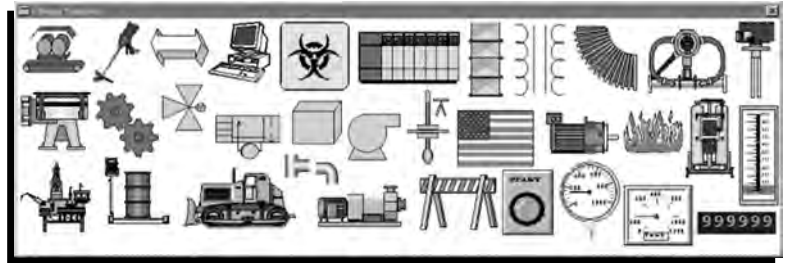

Arrange your toolbars on the top, bottom, middle, or sides of the screen with Floating Palettes.

Key Editing and Drawing Functions Include:

- Lines
- Polylines
- Polygons
- Rectangles
- Rounded Rectangles
- Ellipses & Circles
- Arcs, Pies, Chords
- Text
- Bitmaps
- Buttons
- Windows Metafile Import
- Alarm Displays
- Alarm Logger
- Trend Displays
- Object Grouping
- Editing of Group Objects
- Align ~ Left, Right, Top, Bottom
- Align Middle ~ Horizontal, Vertical
- Space Equal ~ Horizontal, Middle
- Rotate ~ Clockwise, Counter Clockwise
- Make Equal ~ Width, Height
- Bring to Front
- Send to Back
- Z Depth Level 1-10
- Reshape
- Rotate Shapes
- Flip Horizontal or Vertical

Key Animation

Functions Include:

- Visibility ~ Show/Hide
- Change Color
- Blink ~ Fast, Medium, Slow
- Take Action ~ Activate Script
- Rotate Shapes
- Move ~ Horizontal, Vertical
- Stretch ~ Horizontal, Vertical
- Enter Data ~ Boolean, Numeric, String
- Slider ~ Horizontal, Vertical
- Show Value ~ Boolean, Numeric, String

Trend Functions

Infilink-HMI provides built-in Real Time and Historical Trend objects which allow you to quickly add time based views of your process data.

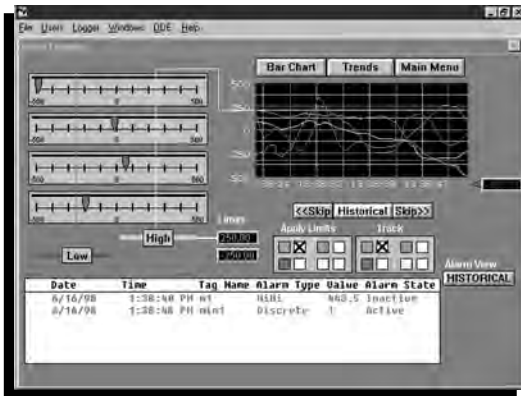

Sample Trending Application

Key Trend Functions Include:

- Multiple Plotting Modes
- Script Control
- Fast Display Speed
- 10 Pens / Trend
- Library Objects for Trend Control

Scripting Language

Infilink-HMI was designed to fit all of your needs with our built in functions. However, we have provided a powerful scripting language allowing you to tailor Infilink-HMI's operation to meet any application requirement.

Key Script Functions Include:

- Project Script ~ (Before, While, After) Open
- Window Scripts ~ (Before, While, After) Open
- Tag Scripts ~ On Data Change
- Conditionals ~ IF, THEN, ELSE
- Logical Operators ~ AND, OR, NOT
- Comments
- File Functions ~ Read, Write, Text, CSV
- Object Property Access
- Conditional Operators
- Full Set of Math and String Functions
- Automatic Error Checking
- Play Wave Files

Data Logging

Any Tag in Infilink's tag database can be configured to log itself to disk. Crucial events can be stored and shared with any application via industry standard database formats.

Key Data Logging Functions Include:

- User Specified Logging Path
- User Controlled Log Enabling
- Log File Change Based On Time
- Improved logging performance
- User Selectable DBASE (DBF) or MS Access (MDB) file formats.

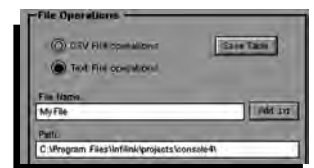

You Asked! We Listened! NEW FEATURE...

"Ragged Tank Cut-Out" has been a typical request which could not be done until now!



Alarm Management and Display

Infilink-HMI provides a complete alarm management and display system available from any window in your application. Operators can view and acknowledge alarm conditions quickly using the alarm object. The Alarm History Viewer allows logged alarm events to be searched and filtered.



Key Alarm Functions Include:

- Limit Alarms ~ LowLow to HighHigh
- Discrete Alarms
- Selectable Priority Levels
- Custom Alarm Messages
- Selectable Filtering on History Viewer
- Automatic Printing of Alarms
- Logging of event with User ID
- Print Selected Alarm History Data

Telephone Alarm Notification



The Infilink telephony feature is a real-time Telephone Alarm Notification system. Infilink can call pagers, cell phones, landline phones and wireless devices to warn operators of alarm conditions. Warnings can be spoken over the phone lines using the SpeakOut "text-to-speech" scripting. Touch tone recognition

allows the operator to send commands to the system using the telephone keypad. This feature is only available with the unlimited tags version.

MS Access (MDB) File Logging

Use your favorite editor or report generation tools such as Excel, Crystal Reports or MS Access, to organize or analyze your data.

OPC Client

OPC (Object Linking and Embedding for Process Control) is now the standard format for industrial communication drivers. We have added OPC Client functionality to Infilink-HMI. Now you can use any of the OPC communication servers on the market with our product. We recommend using the KEPSWare Extreme OPC servers, but you can use the OPC server product of your choice. Infilink also supports AdvancedDDE and NetDDE.

There's An Easier Way to Make Infilink-HMI Speak!

New Text-to-Speech (TTS) functionality lets Windows XP users read a string tag over speakers, into a PA system, or through a telephone mode. Infilink's SpeakOut command scripting prompts you to insert text and repetitions. This feature is only available with the unlimited tags version.



Other Features:

Software Based Protection

Infilink-HMI uses a software based keying system which works on any Windows operating system.

Multi-Platform Operation

Infilink-HMI runs with Windows 98SE, Windows 2000 and Windows NT.

System Requirements

Operating System:

Windows XP (preferred), 2000, NT 4.0, 98SE.

Disk Space:

50MB Free Disk Space

Screen Resolution:

640x480 (minimum), 800x600 or higher (preferred).

Ordering Information

Runtime Packages with the following Real I/O Tag counts are available:

128 I/O Tag Runtime **Part # KEPRUN-128**

Includes any 1 KEPServerEX OPC Server PLC Driver at no additional charge.

256 I/O Tag Runtime **Part # KEPRUN-256**

Includes any one KEPServerEX OPC Server PLC Driver at no additional charge.

512 I/O Tag Runtime **Part # KEPRUN-512**

Includes any one KEPServerEX OPC Server PLC Driver at no additional charge.

Unlimited I/O Tag Runtime **Part # KEPRUN-0000**

Includes any one KEPServerEX OPC Server PLC Driver at no additional charge.

Note: Internal or Memory tags are not counted as part of your licensed tag count.

Download a fully functional version of Infilink-HMI from our website at:

www.kep.com

KEP ServerEX

High Performance OPC Server Software

Description

KEP ServerEX is the latest generation of KEPware's OPC server technology. Building upon the original KEPServer, KEP ServerEX has incorporated many of the features requested by KEPware's customers. In addition to customer driven enhancements, many technological changes have occurred. These features and enhancements have all been made with the goal of providing an OPC server that demonstrates unparalleled compatibility and performance. A few of the enhancements are transparent to the user, but there are a number of new features that are readily apparent and directly available to the user. The following sections will describe the primary features of KEP ServerEX.

Application Connectivity

KEP ServerEX supports the following client server technologies:
 OPC Data Access Version 1.0a & 2.0
 DDE Format CF_Text, XL_Table & AdvancedDDE

Device Connectivity

KEP ServerEX allows you to use a number of communications drivers concurrently.

Runs as NT Service

KEP ServerEX supports running as a service under Windows NT/2000. Service operation is completely user configurable from the Tools|Options menu and can be changed at any time allowing you to move from normal stand alone program operation to NT service mode.

Data Scaling

KEP ServerEX now supports direct scaling of device data. Scaling allows raw device data to be converted to engineering units for OPC client applications. KEP ServerEX provides a number of unique scaling features that make it easy to implement scaling in your application.

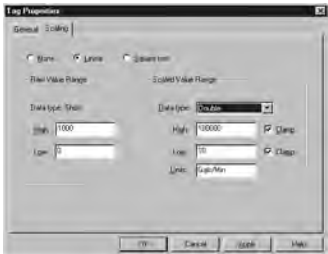

On-Line Full Time

The full time on-line mode of operation allows a KEP ServerEX project to be modified while the server continues to supply data to client applications. Almost every parameter can be changed while the server is operating.



User Management

KEP ServerEX includes a built-in User Manager that allows complete control over what types of functionality each individual user can access.

Tag Management

KEP ServerEX's new user defined tag management features allow you to create a tag database structure that fits the nature of your application.

Automatic Tag Database Generation



The Automatic Tag Database Generation feature brings OPC technology one step closer to Plug and Play operation. Drivers that support this feature can either read tag information directly from a device or generate tags from stored tag data.

Diagnostics

KEP ServerEX's new diagnostic features provide real-time data on the performance of your communication driver. All read and write operations can be viewed in the diagnostic display window of KEP ServerEX or can be tracked directly in your OPC client application by using its built-in diagnostic tags.



Modem Support

KEP ServerEX supports the use of modems on all serial communication drivers. Modem control is provided by a set of new modem tags.

OPC Quick Client

KEP ServerEX includes an extensive OPC Quick Client application to aid in the development your OPC applications.

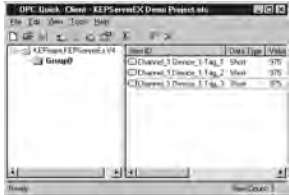

Visual Basic Examples

The simple and complex VB examples included with KEP ServerEX are well commented and provide additional pointers for using OPC servers in your VB applications.

System Requirements:

	Minimum	Recommended
Operating System:	Windows 98	Windows NT 4.0 SP5 or better
Processor:	Pentium 200Mhz	Pentium 400Mhz
Ram:	32 MB	64 MB
Disk Space:	10 MB	10 MB

NOTE: While KEP ServerEX will run on Windows 95 and Windows 98 we strongly recommend the use of either Windows NT 4.0 SP5 or Windows 2000 for use in industrial applications.

S12 Dip switch settings

- 1 - Parallel or Multiplex input mode
- 2 - Input polarity (positive or negative true)
- 3, 4, 5 - Decimal point location
- 6 - Extended characters (A~F or ì-, E, H, L, P, (BLANK)
- 7, 8 - Noise filtering.

Wiring

TERMINAL ADAPTOR "X"

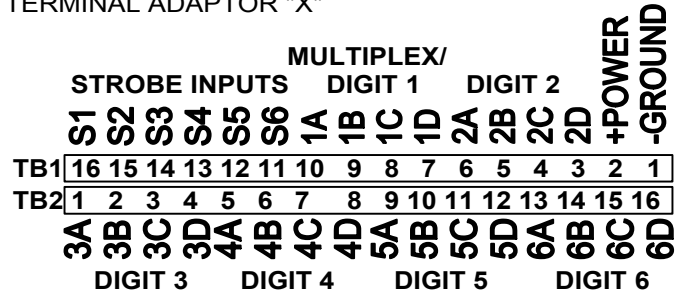

4 DIGIT UNITS HAVE DISPLAY CENTERED
 WIRE DATA AND STROBES TO DIGITS 2 THROUGH 5

Dimensions:

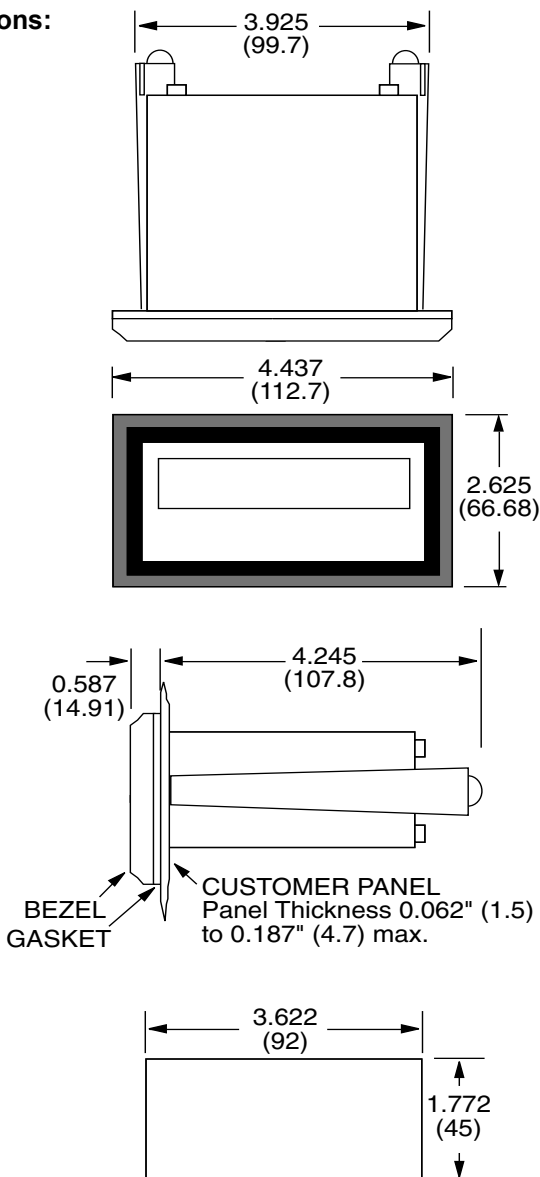

How To Order:

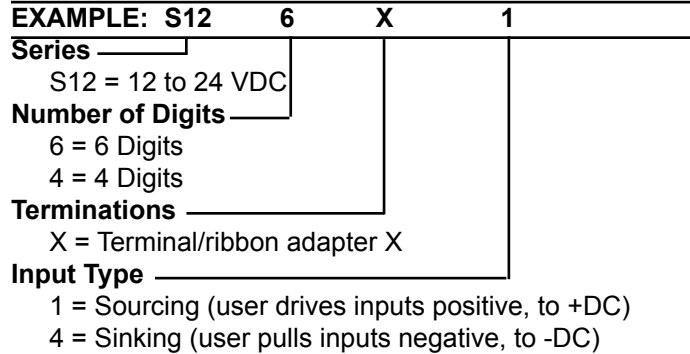

Accessories

S12 RIBBON FOR ADAPTER "X"

Ribbon is continuous with connectors attached each 12 inches.

Part Number: S12RX__ Specify number of units to be linked together.

Example: #S12RX4 is cable to connect four S12 units spaced 12 inches apart.

S12 ADAPTER "X" FOR RIBBON CABLE

(Supplied as termination "X" when ordered on S12 display)

May be ordered separately #S12AX.

May be used at PLC to convert ribbon cable to screw terminal.

*** SPECIAL LENGTH ORDER FORMAT**

S12RX - Specify ribbon lengths between connectors in 6 inch increments using alphabet letters to indicate number of 6" intervals. Eg. A=6", B=12". C=18", etc. List the interval between the top display and next highest first, then list lower ones in order. S12RXACCB is a ribbon to connect 5 displays with 6" between 1st (top) and 2nd, 18" between 2nd and 3rd, 18" between 3rd and 4th, 12" between 4th and 5th (bottom).

Mounting:

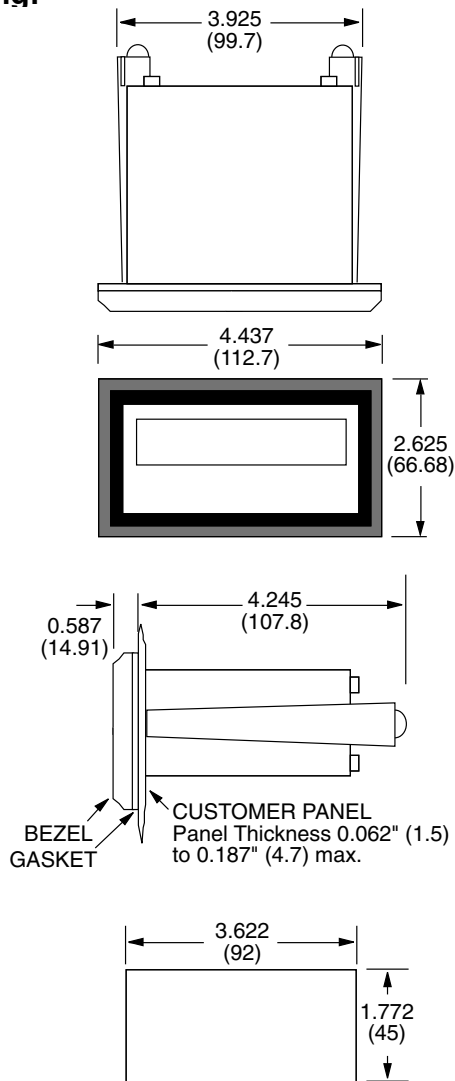

NOTE: Allow an additional 0.75" in depth when using the "PC90PT" series ribbon adaptors

Wiring:

Each unit is shipped with a 12 terminal, two piece, male/female connector.

- 1 • BCD Data 1
- 2 • BCD Data 2
- 3 • BCD Data 4
- 4 • BCD Data 8
- 5 • Digit Select 1
- 6 • Digit Select 2
- 7 • Digit Select 4
- 8 • Decimal Point
- 9 • Display Select 1
- 10 • Display Select 2
- 11 • (+) DC Power
- 12 • (-) DC Power

How To Order:

EXAMPLE: PC 9	7	B	7	4
Series				
Power Supply				
7 = 5 VDC (regulated) ±5%				
9 = 10 to 24 VDC				
Display Mode				
H = Hexadecimal 0-9, A, b, C, d, E, F				
B = B Code Standard 0-9, -, E, H, L, P. (blank)				
Decimal Point				
1 = xxxxx.x				
2 = xxxx.xx				
3 = xxx.xxx				
4 = xx.xxxx				
5 = x.xxxxx				
7 = Software selectable				
Options				
4 = "Sinking" input (for use with sinking output modules)				

Accessories

PC90PTX: To connect to Programmable Controller (must have 1)

PC90PTY: To connect up to three additional PC_9000's

PC90PTZ:

NOTE: Order sufficient quantity and lengths of cable. See standard ribbon cable chart below.

STANDARD RIBBON CABLE LENGTHS

ORDER	LENGTH
Z6	6"
Z12	12"
Z18	18"
Z24	24"
Z48	48"

10 Conductor Color-Coded Cable -

TWTB/TWSTB

BCD Thumbwheel Switches



Description:

The TWTB Series is sealed internally to protect against dust, dirt, and moisture. The TWSTB thumbwheel switch is sealed against dust and dirt only. A plastic window covers each digit. Each .500" wide switch is sized for comfortable operation while saving space. They accept voltages up to 120 VAC. They are also available with diode isolation for use with multiplexing. Screw mounting hardware and screw terminal block connections are standard.

Specifications:

- No. of switching positions 10, numbered 0 through 9
- Life..... Greater than 100,000 detent operations
- Tangential Operating Force 6-20 oz.
- Temperature Range -10°C to +65°C
- Electrical Ratings:
 - Non-Switching Load 1 Amp/common terminal
 - Switching load..... 0.125 amps at 115 VAC or 28 VDC
- Dielectric Withstanding Voltage ... 500 V (RMS)
- Insulation Resistance..... 1000 MOhms (min.)
- Switch Circuit Resistance 0.100 Ohms (max.)
- Weight 0.40 oz. (Approx.) per decade
- Standard Color..... Black
- MATERIALS:**
 - Plastic..... ABS plastic
 - Circuit Board Glass epoxy (g-10)
 - Contacts
 - Rotary Precious metal over copper alloy
 - Stator Gold over nickel over copper
 - Form..... BCD 1-2-4-8 with diodes for multiplexing

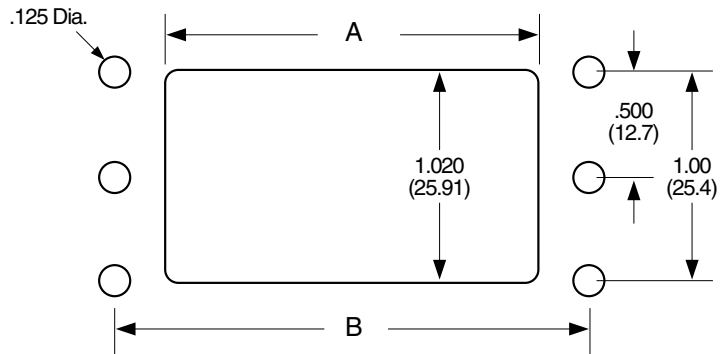
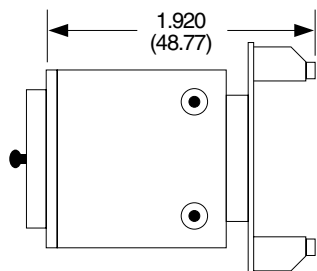
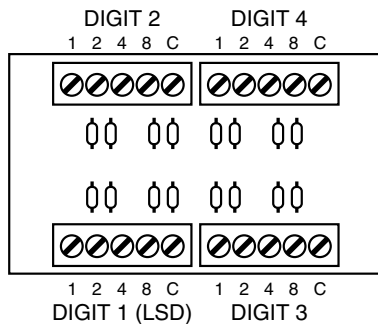

A	B
$(.50 \times N) + .340$	$(.50 \times N) + .560$
$(12.7 \times N) + 8.64$	$(12.7 \times N) + 14.22$

Dimensions:

RECOMMENDED CUTOUT DIMENSIONS

TW. SWITCHES	A	B	C	D	E*
2 TW SW	3.250	.625	2.000	—	3.625
3 TW SW	3.250	.157	2.937	—	3.625
4 TW SW	3.250	.157	2.937	—	3.625
5 TW SW	4.750	.470	3.812	—	5.125
6 TW SW	4.750	.470	3.812	—	5.125
7 TW SW	4.750	.063	4.625	—	5.125
8 TW SW	6.250	.625	5.000	3.125	6.625
9 TW SW	6.250	.188	5.875	3.125	6.625
10 TW SW	6.250	.188	5.875	3.125	6.625

NOTES:
SWITCH MOUNTING PLATE O.D. DIMENSIONS FOR REFERENCE ONLY MARKED WITH *

RECOMMENDED WHEN USING SWITCHES WITH MOUNTING PANEL OPTION (MP)

Polarities:

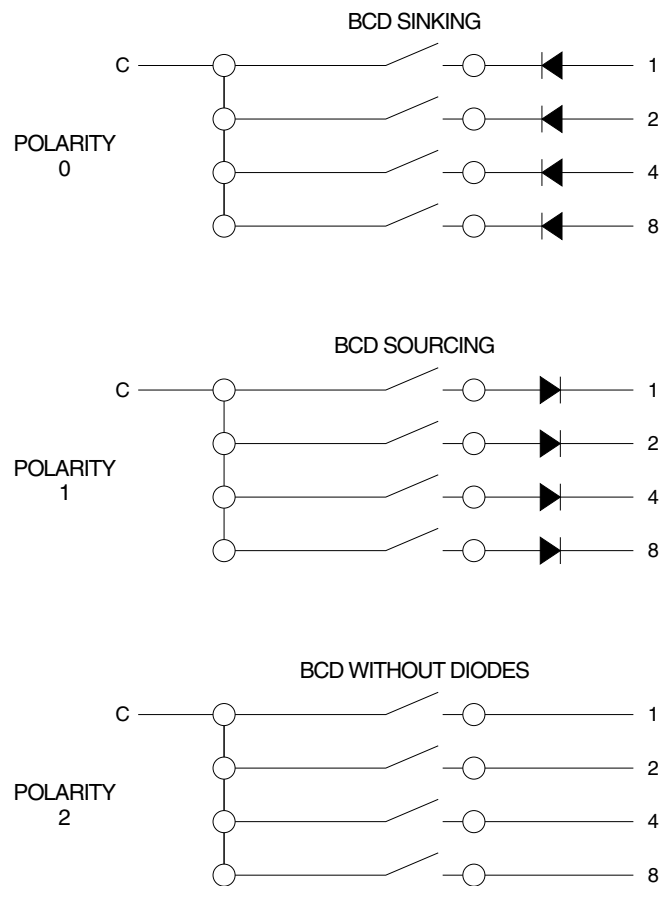

How To Order:

EXAMPLE: TWTB 4 0 MP

Series TWTB: Moisture sealed
TWSTB

Number of Digits 1 through 10

Blank To order blanks: state the # of digits before, "X" (blank), then the # of digits after. EX: TWTB 2X2 0 is a thumbwheel with 2 digits, a blank, 2 more digits & polarity 0

Decimal To order decimals: state the # of digits before, "." (decimal), then the # of digits after. EX: TWTB 2.2 0 is a thumbwheel with 2 digits, a decimal, 2 more digits & polarity 0

Polarity 0,1,2

Option MP-Mounting Panel

RSW

BCD Rotary Switches

Features

- Withstands hose down when enclosed by NEMA 4X / IP65 housing
- Nontoxic exposed parts
- BCD output with or without diode blocking
- Large knob, easy to operate
- Large number display
- Heavy duty

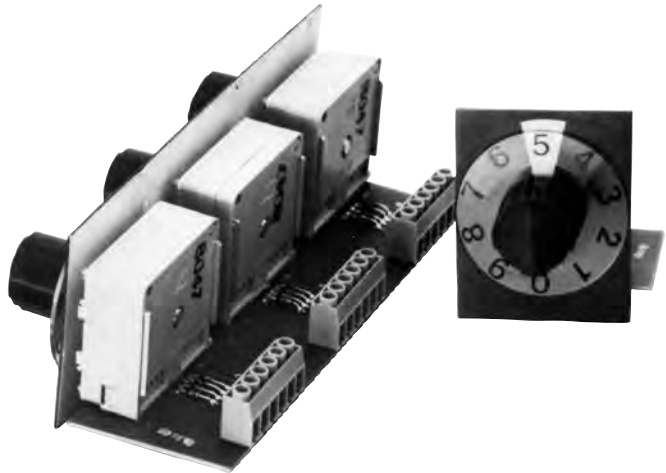

Application:

For inputting numerical data to counters and timers in PLC's. Suitable for all industries including food and pharmaceuticals.

Description:

The KEP rotary switches are available in 1 through 6 decades. They are heavy duty switches numbered 0 through 9, and meets NEMA 4X/IP65 ratings. The BCD outputs, complete with blocking diode, are suitable for input connection to almost any programmable controller.

The rotary switches are used to input production count, correction factors, times, etc. into registers. Large numbers, stainless steel shafts, large knobs and Buna-N seals permit use in a variety of environments.

The switches are not affected by hose down, even with most caustic additives.

Specifications:

No. of switching positions	10, numbered 0 through 9
Life.....	Greater than 500,000 detent operations at 25° C for a resistive load of 0.125 Amps at 48 VDC
Rotational Operating Force	14 to 24 ounce-inches
Operating temp range.....	67°F (-55°C) to +185°F (+85°C)
Electrical Ratings:	
Max. Recommended non switching load.....	0.250 Amps at 115 VAC or 48 VDC
Min recommended switching load	0.125 Amps at 115 VAC or 48 VDC
Insulation resistance	100 MOhms (min. dry)
Switch circuit resistance	0.100 Ohms max. initial 0.200 Ohms max. after life test
Size of digit.....	0.22"h; numbered 0 through 9
Number of decades	1 through 6
Color of digits	Black on white background
Knob diameter.....	0.83"
Connection.....	Screw terminal block

MATERIALS

Seal Buna-N Shaft Seals

Materials:

Plastic	Thermo-Plastic, meets U.L. 94V-0
Circuit Disc	Glass epoxy, gold over nickel
Metals	Corrosion resistant stainless steel
Number Dial	Luran
Overlay	Adhesive backed Mylar

Recommended maximum

panel thickness

up to 14 gauge, .075"
(1.9mm)

Terminal Connector (each digit):

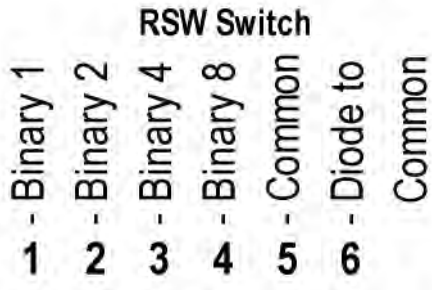

Mounting:

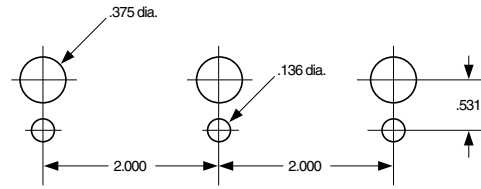

DIMENSION IS TYPICAL FOR HOW MANY SWITCHES ORDERED

Polarities:

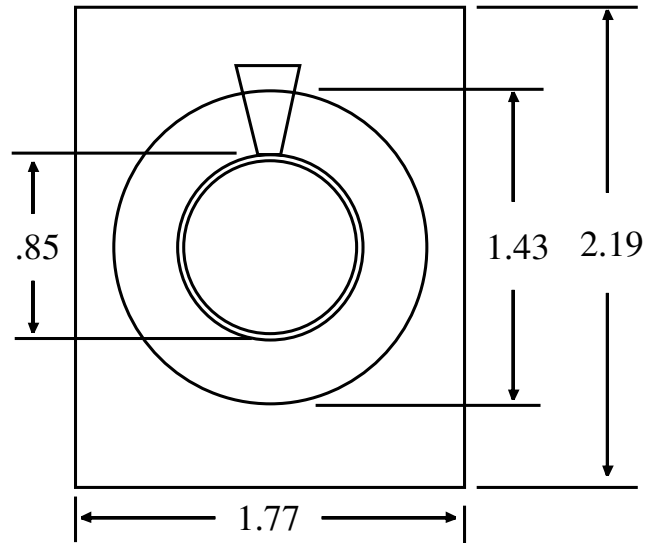
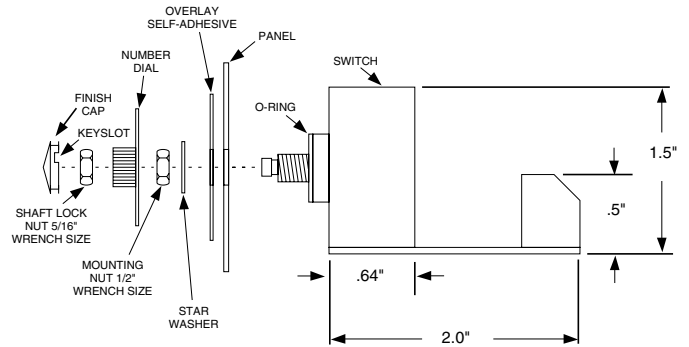
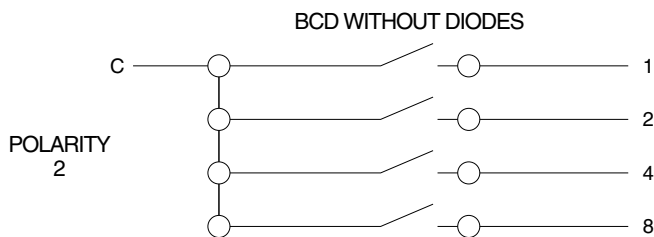
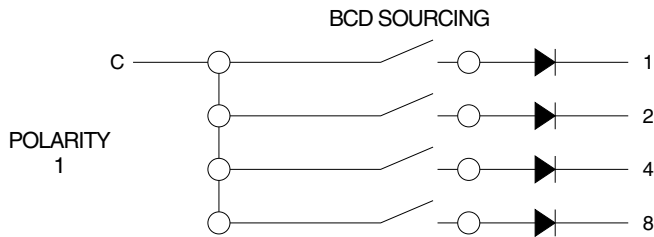
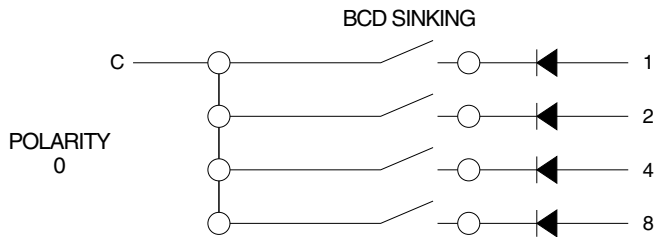

How To Order:

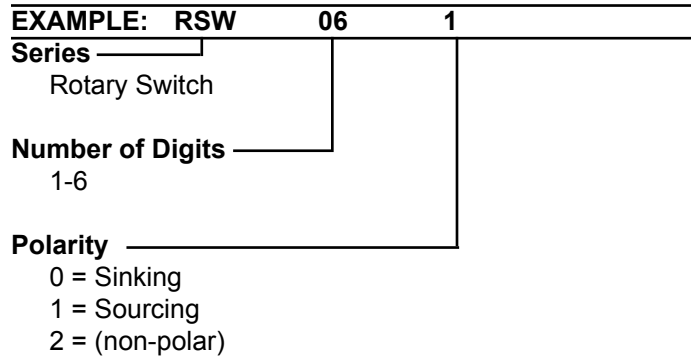

SMIC Cables

Smart Interface Cables for KEP Operator Interfaces

Product Overview:

The SMIC cable is designed for connecting a ZOIDDX, IMC2 or MMI series to a PLC.

Networking:

The SMIC cable is designed to communicate as a one to one device. Networking is not supported with standard SMIC cables. If networking is needed for more than one Operator Interface, consult factory for special cable requirements.

Caution:



Restrict cable length to less than 500' (150m) for RS485/422 devices and 50' (15m) for RS-232 devices to avoid communications problems.

Communications problems cause the ZOIDDX, IMC2 and MMI display to hold until communications can be established.

Shielded cable must be used for long lengths or cables run in an electrically noisy environment. Do not run cables next to AC power lines or near sources of electrical noise.

Be sure that the cable ends have been inserted all of the way into mating connectors and are secure.

Note:

The SMIC cables with electronics, should only be extended at the PLC end of the cable.



Ordering Information

The KEP part numbers have the SMIC prefix followed by the PLC driver name and the length of cable in feet.

Example:	SMIC	MOD	-05
Prefix Type	SMIC		
	SMIC15		
PLC Type			
	(see following page)		
Cable Length			
	-05 = 5 feet		
	-10 = 10 feet		

NOTE:

Refer to the following page for a complete list of SMIC cable compatible devices.

SMIC Production Possibilities

Cable	PLC Compatibility	MMI-1XX/2XX	MMI-430, 730, 850, 1500	MMI8000 Series	ZOID-DX
SMICAB500	All Allen Bradley SLC500 types with DH485 port	X			X
SMIC15AB500	All Allen Bradley SLC500 types with DH485 port		X	X	
SMICABMICRO	Allen Bradley MicroLogix only	X	X		X
SMICABAIC	For use with Allen Bradley AIC Modules	X			X
SMICABDF1	Allen Bradley SLC5/03, 5/04 with DF1 port	X	X		X
SMICARO	All Aromat FP1 Series PLC's	X			X
SMICFUJI	Fuji Flex Series NB, NJ and NS	X			X
SMICGE90	All GE 90 Series SNP Port	X			X
SMIC15GE90	All GE 90 Series SNP-X Port		X	X	
SMICIDECM1	IDEC Micro 1 Series only	X			
SMICIDECM3	IDEC Micro 3 Series only	X			X
SMIC15IDECM3	IDEC Micro 3 Series only		X	X	
SMICIDECM3C	IDEC Micro 3C Series only	X	X		X
SMICK205	Koyo DL230, 240, 250	X	X		X
SMICK305	Koyo 340, Siemens 335, 337	X			X
SMICK405	Koyo 440, Siemens 425, 435	X	X		X
SMICKEY	All Keyence KV series	X			X
SMICMOD	All PLC's and controllers with DB9 MODBUS RTU ports	X	X		X
SMICMODMICRO	Modicon Micro 984	X	X		X
500_AnS	Mitsubishi A Series		X		
SMICMITFX	Mitsubishi FX Series	X			X
SMIC15MITFX	Mitsubishi FX Series		X	X	
SMICMITFXO	Mitsubishi FXo only	X			X
SMIC15MITFXO	Mitsubishi FXo only		X	X	
SMICOMCK25	Omron C series (Host Link Modules)	X			X
SMICOMCH9	Omron CH Series	X			X
SMICOMCQM	Omron CQM1 Series	X	X		X
SMIC5S5	Siemens S5 Series	X			X
SMIC5S7	Siemens S7 200 Series only	X			X
SMIC15S7	Siemens S7 200 Series only		X	X	
SMICTSBT1	Toshiba T Series T1 only	X	X		X
SMICTSBT2	Toshiba T Series T2, T3	X			X
SMICTSX07	Telemecanique TSX 07 (nano) Series	X			X
SMIC15TSX07	Telemecanique TSX 07 (nano) Series		X	X	
SMICTSX17	Telemecanique TSX 17 Series	X			X
SMICTSX47	Telemecanique TSX 47-40, 47-20	X			X